



NINGBO SHUNXINGKAIHAO MACHINERY CO., LTD.  
No.1 GehechenDonggangqiXiaogangBeilun, NingboCHINA  
Mob(MrCai): +86 13958333666  
Tel:+86 574 86191888 Fax: +86 574 86191988  
Email: Sales@sunycal.com Oversea Dept. [Colincai@sunycal.com](mailto:Colincai@sunycal.com)  
[www.sxkhglobal.com](http://www.sxkhglobal.com)

### Branch

#### SXKH (ShenZhen, China)Office

Address: BaoAnDistrict,Shenzhen, CHINA  
Mob(MrLi) : +86 13777039558

#### SXKH (Shanghai, China)Office

Address:Minhang District,Shangahi, CHINA  
Mob(MrCai) : +86 13764527409

#### SXKH AUTOMATION INDIA PRIVATE LIMITED

Address: 905, Pearles Best Height-1,A5  
Netaji Subhash Place, Pitamura, New Delhi  
Mob(Mr Pankaj Goel): +91 9810299598  
Email: Pankaj@sxkhindia.com

### Representative:

#### Portugal and Spain

Impor4Mill, Lda  
Address: Rua de S o Pedro, Lote 1, n°139,  
2430-164 Marinha Grande | Portugal  
Telm (Ricardo Pedrosa) +351 961 580 731  
Email: geral@impor4mill.pt

#### United State and Canada:

Dynamic International Inc  
Address: N25 W23287 Paul RoadPewaukee, WI 53072, USA  
Phone: (262)521-1100  
Email: layo@dynamicintl.com



# DIE SPOTTING PRESS



NINGBO SHUNXING KAIHAO MACHINERY CO.,LTD.





# Company Profile

Ningbo ShunXingKaiHao(SXKH) Machinery Co., Ltd. is located in Ningbo city. The company insists on “Honesty Centered, Quality first, Independent Innovation and Scientific Development”, and mainly engages in researching, manufacturing and selling of mechanical, electronic, hydraulic as well as automatic control equipment. The products include Die Spotting Machine, Mold Flipper, Quick Die Change System, including Hydraulic Clamp, Electro-permanent Magnetic Chuck.

Ever since it has been founded, the company attaches great importance to the development of innovation and quality management. With strong technical force, complete processing equipment and advanced management team, the whole process is strictly supervised by ISO9001 QMS, which ensures both, products' quality and technological advancement. The company obtains many proprietary intellectual property rights and has made great achievements over the past years, and finally formed a perfect marketing network, which covers the domestic as well as European and American markets. “Credit first, Quality first” is the management policy that Ningbo ShunXingKaiHao Machinery Co., Ltd. always holds. The company also believes that superior quality, excellent service.

# Contents

PAGE	
01-04	Company Profile
05-06	Operation and Market
07-08	HMG-ES Two way
09-10	HMG-ES One way
11-12	Specification & Function
13-14	NEW for ES Series
15-16	The Customer site
17-18	Accessory Machine- Mold Flippers
19	Accessory Machine -Mold inspection machine
20	Client List
21-22	SXKH







# SXKH

## Development history

### 2003

ShunXing Brand was founded by Mr. GuangShun Cai in Ningbo City to invent and produce Die Spotting press

### 2005

The 1st Four guide-pillar type die spotting press “JM” Series was invented and manufactured by our team in Asia Region. We successfully invented the 1st four-guide pillar type die spotting machine HMG-JM series domestically.

### 2006

Hydraulic Clampers for injection molding machine were launched in Chinese market

### 2009

The new plant went into operation and register Ningbo ShunXingKaiHao (SXKH) Machinery Co., Ltd as new company name. SXKH believe in “Honesty Centered, Quality First, Independent Innovation and Scientific Development as company’s management principle. The whole process is strictly supervised by ISO9001 QMC. SXKH obtains many Patents right and CE certification for all the products.



SXKH Sales Volume

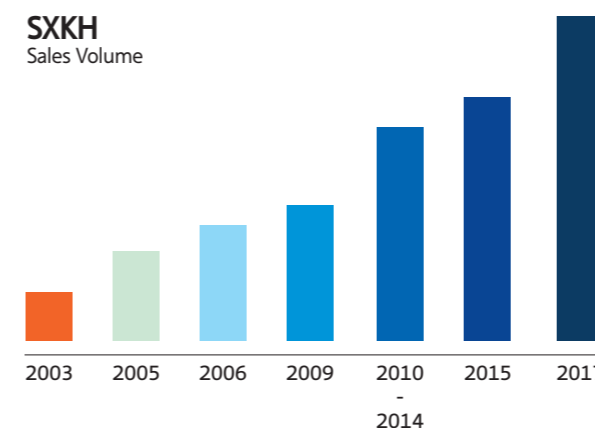

### 2010-2014

SXKH Opened offices in seven different cities in China, such as Shenzhen, Shanghai, to extend prompt after sales support to all customer across China. During this period, we delivered 2 largest 600Tons with 4000mm x 2500mm table size Die spotting press to FAW. At same time, SXKH won the another 528Ton die spotting press bidding from China Aerospace, due to its cutting-edge technology, superior quality and excellent service and based on good fame and reputation from cooperation with FAW and Hisense.

### 2015

SXKH begins international market exploration and signs strategic cooperating plan with famous European, Indonesian, Indian, Thailand and South American electromechanical company. In the next 5 years, SXKH will be NO.1 brand in high precision Die spotting press.

### 2017

SXKH Set up Branch company SXKH Automation India at New Delhi, India. In the following year, SXKH India company not only provide local sales and after-sales service, but also provide global service. Establish cooperative relationship with IMPOR4MILL Portugal, Mainly in Charge of Portuguese and Spanish market; Cooperate with Dynamic USA, Mainly in charge of North American market.



# Operation and Market

## Operation Center:

- Head office SXXH Ningbo China
- SXXH Automation INDIA New Delhi INDIA
- Southern China Branch Shenzhen China Office
- Eastern China Branch Shanghai China Office

## Representative:

- |                 |                         |               |
|-----------------|-------------------------|---------------|
| • <b>Europe</b> | • <b>North American</b> | • <b>Asia</b> |
| Spain           | United State            | Thailand      |
| Portugal        | Canada                  | India         |
| Italy           | Mexico                  | Taiwan China  |
| Turkey          |                         |               |



We wish to have our presence across the world. We welcome new sales partners to join hands with SXXH to help us reach out to global industries.

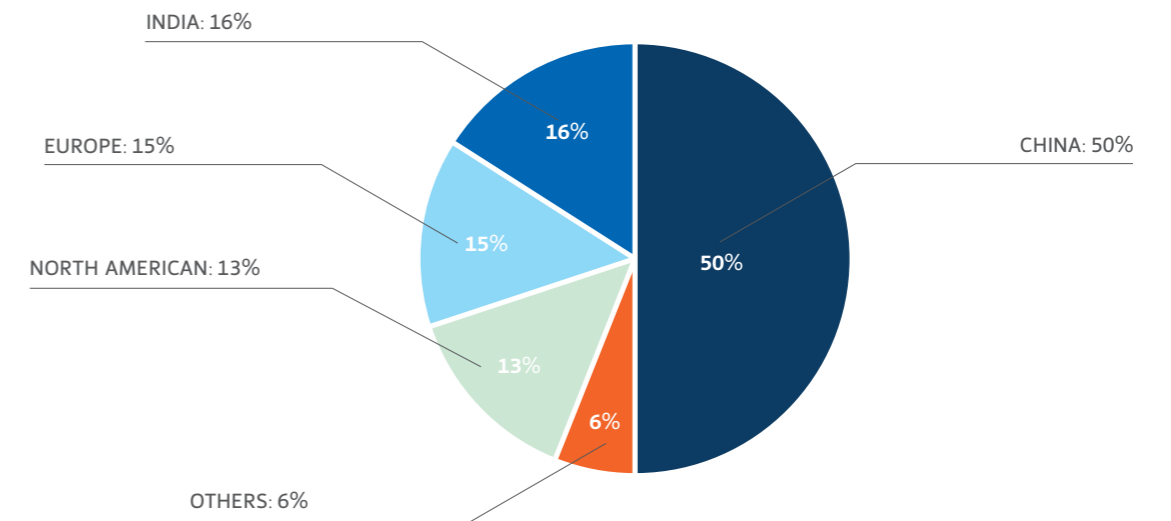

Year 2015, Mumbai India



Year 2015 Portugal



Year 2018, Gujarat India



Year 2018 Spain





◀ Optional Right Side ▶

◀ Standard Left Side ▶

#### HMG-90ES ~ HMG350ES

Max. Clamping force	KN	900	1600	2000	3000	3500
Max. Opening Force	KN	215	400	500	700	1000
Load capacity on upper platen	kg	3000	10,000	15,000	22,000	26,000
Load capacity on lower platen	kg	5000	16,000	30,000	42,000	50,000
Platen Dimension	mm	1200×1100	1600×1400	2000×1600	2500×2000	3000×2000
Distance Between Pillars	mm	1465	1880	2280	2890	3370
Max. daylight	mm	1500	1800	2000	2500	2700
Min. daylight	mm	150	200	200	400	400
Overturn degree for upper platen	°	180/100	180/100	180/100	180/100	180/100
Ejector testing stroke/capacity	mm/KN	220/30	250/70	250/100	250/100	300/100
Machine Dimension	mm	3600×3850 ×4750	4600×4400 ×5500	5400×4600 ×6000	6800×5700 ×7300	7600×5670 ×7850
Total Weight (About)	kg	15,000	28,000	36,000	61,000	85,000

#### HMG-400ES ~ HMG600ES

Max. Clamping force	KN	4000	4000	5000	5000	6000
Max. Opening Force	KN	1000	1500	1600	1600	1600
Load capacity on upper platen	kg	32,000	32,000	40,000	50,000	50,000
Load capacity on lower platen	kg	60,000	70,000	80,000	90,000	90,000
Platen Dimension	mm	3100×2100	3500×2500	4000×2500	4000×3000	4000×3000
Distance Between Pillars	mm	3470	3900	4400	4400	4400
Max. daylight	mm	3000	3200	3200	3700	3700
Min. daylight	mm	400	400	400	400	400
Overturn degree for upper platen	°	180/100	180/100	180/100	180/100	180/100
Ejector testing stroke/capacity	mm/KN	300/120	300/120	300/120	300/120	300/120
Machine Dimension	mm	8000×6070 ×8600	8900×6400 ×9400	9900×6400 ×9600	9900×7500 ×10400	9100×7500 ×10400
Total Weight (About)	kg	110,000	130,000	150,000	180,000	180,000

	HMG-90ES	HMG-160ES	HMG-200ES	HMG-300ES	HMG-350ES
Max. Clamping force	900	1600	2000	3000	3500
Max. Opening Force	215	400	500	700	1000
Load capacity on upper platen	3000	10,000	15,000	22,000	26,000
Load capacity on lower platen	5000	16,000	30,000	42,000	50,000
Platen Dimension	1200×1100	1600×1400	2000×1600	2500×2000	3000×2000
Distance Between Pillars	1465	1880	2280	2890	3370
Max. daylight	1500	1800	2000	2500	2700
Min. daylight	150	200	200	400	400
Overturn degree for upper platen	180/100	180/100	180/100	180/100	180/100
Ejector testing stroke/capacity	220/30	250/70	250/100	250/100	300/100
Machine Dimension	3600×3850 ×4750	4600×4400 ×5500	5400×4600 ×6000	6800×5700 ×7300	7600×5670 ×7850
Total Weight (About)	15,000	28,000	36,000	61,000	85,000

	HMG-400ES	HMG-400ES -3525	HMG-500ES -4025	HMG-500ES -4030	HMG-600ES -4030
Max. Clamping force	4000	4000	5000	5000	6000
Max. Opening Force	1000	1500	1600	1600	1600
Load capacity on upper platen	32,000	32,000	40,000	50,000	50,000
Load capacity on lower platen	60,000	70,000	80,000	90,000	90,000
Platen Dimension	3100×2100	3500×2500	4000×2500	4000×3000	4000×3000
Distance Between Pillars	3470	3900	4400	4400	4400
Max. daylight	3000	3200	3200	3700	3700
Min. daylight	400	400	400	400	400
Overturn degree for upper platen	180/100	180/100	180/100	180/100	180/100
Ejector testing stroke/capacity	300/120	300/120	300/120	300/120	300/120
Machine Dimension	8000×6070 ×8600	8900×6400 ×9400	9900×6400 ×9600	9900×7500 ×10400	9100×7500 ×10400
Total Weight (About)	110,000	130,000	150,000	180,000	180,000

#### Workflow

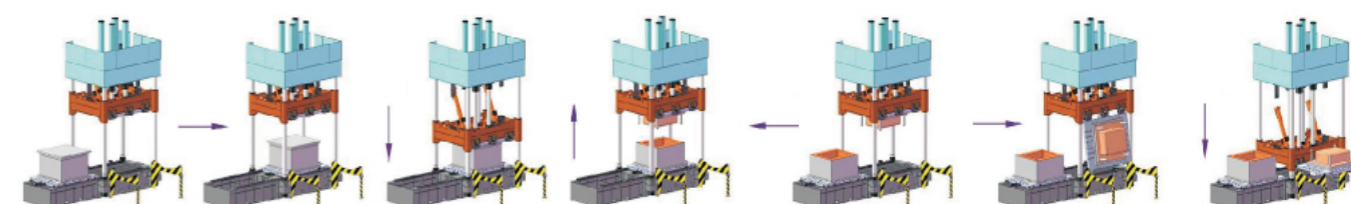



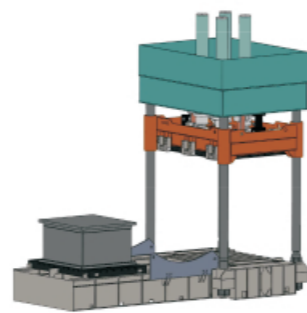
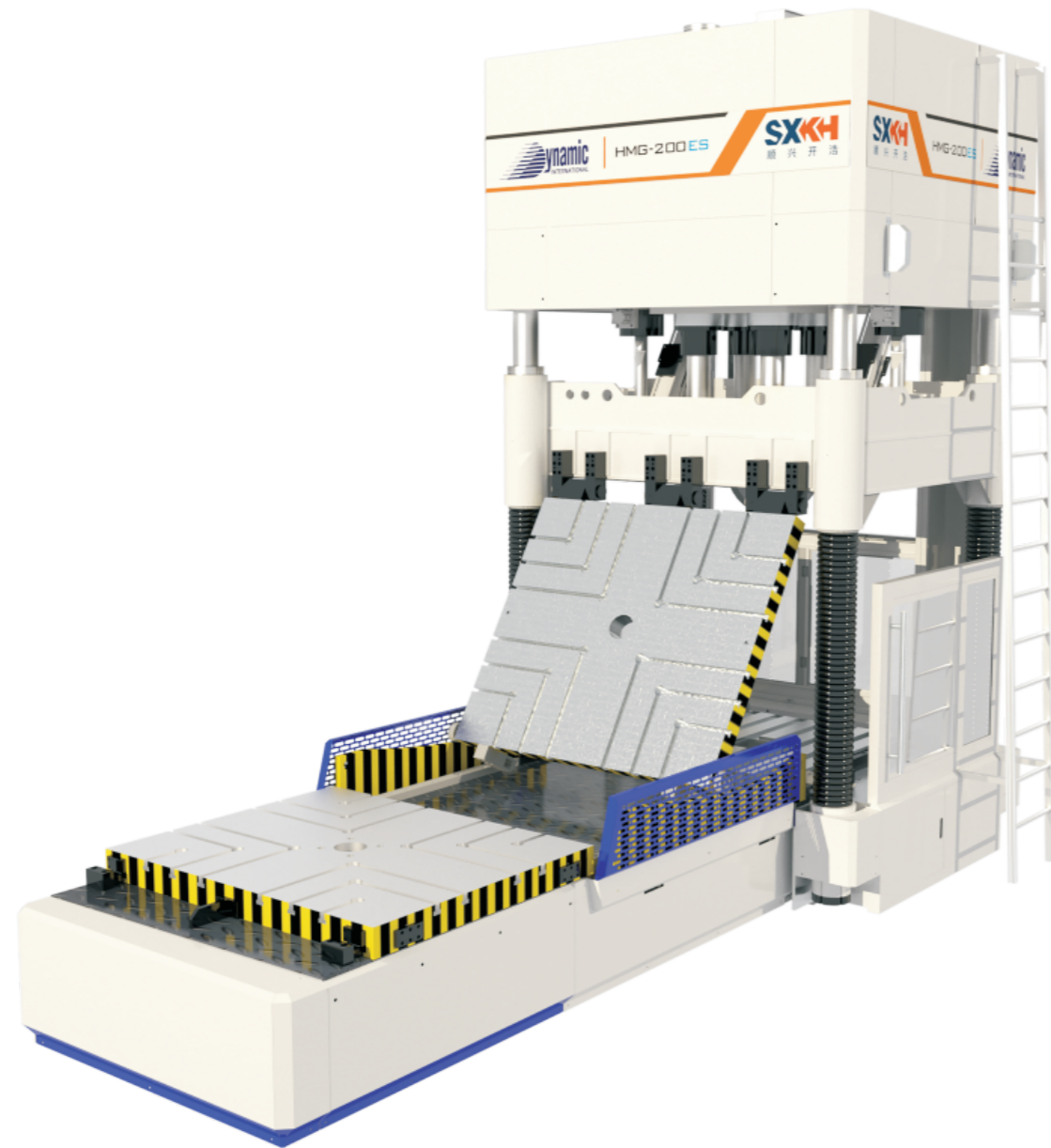

◀ Standard: One way ▶

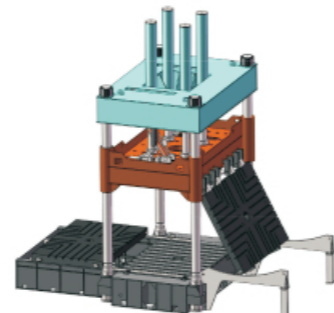

◀ Optional Opposite Way ▶

**HMG-90ES ~ HMG350ES**

Max. Clamping force
Max. Opening Force
Load capacity on upper platen
Load capacity on lower platen
Platen Dimension
Distance Between Pillars
Max. daylight
Min. daylight
Overturn degree for upper platen
Stroke for ejector testing
Machine Dimension
Total Weight (About)

	HMG-90ES	HMG-160ES	HMG-200ES	HMG-320ES	HMG-350ES
KN	900	1600	2000	3000	3500
KN	215	400	500	700	1000
kg	3,000	10,000	15,000	22,000	26,000
kg	5,000	16,000	30,000	42,000	50,000
mm	1200×1100	1600×1400	2000×1600	2500×2000	3000×2000
mm	1465	1880	2280	2890	3370
mm	1470	1800	2000	2440	2640
mm	170	200	200	340	340
°	180/100	180/100	180/100	180/100	180/100
mm/KN	220/30	250/70	250/10	250/100	300/100
mm	5400×2000 ×4750	6000×2650 ×5500	6600×2950 ×6000	8100×3600 ×7300	7600×5670 ×7850
KN	15,000	28,000	36,000	61,000	85,000

**HMG-400ES ~ HMG600ES**

Max. Clamping force
Max. Opening Force
Load capacity on upper platen
Load capacity on lower platen
Platen Dimension
Distance Between Pillars
Max. daylight
Min. daylight
Overturn degree for upper platen
Ejector testing stroke/capacity
Machine Dimension
Total Weight (About)

	HMG-400ES	HMG-400ES -3525	HMG-500ES -4025	HMG-500ES -4030	HMG-600ES -4030
KN	4000	4000	5000	5000	6000
KN	1000	1500	1600	1600	1600
kg	32,000	32,000	40,000	50,000	50,000
kg	60,000	70,000	80,000	90,000	90,000
mm	3100×2100	3500×2500	4000×2500	4000×3000	4000×3000
mm	3470	3900	4400	4400	4400
mm	3000	3200	3200	3700	3700
mm	400	400	400	400	400
°	180/100	180/100	180/100	180/100	180/100
mm/KN	300/120	300/120	300/120	300/120	300/120
mm	8000×4300 ×8650	10100×4900 ×9400	10100×4900 ×9600	11600×5400 ×10400	11600×5400 ×10400
kg	112,000	132,000	153,000	180,000	180,000

**Workflow**

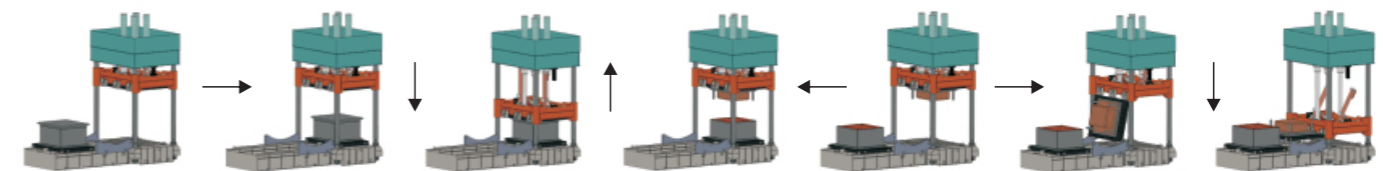

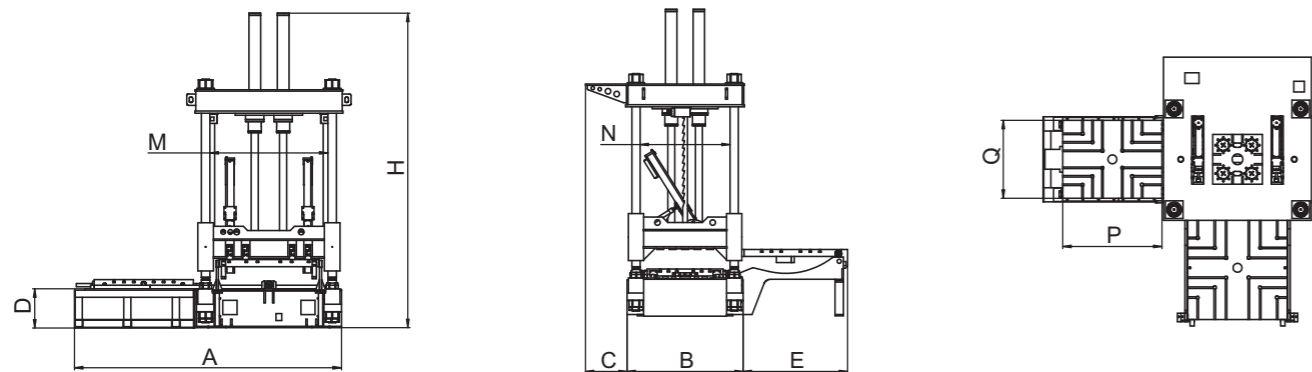

Two way Machine	A	B	C	D	H	M	N	E	P	Q
HMG-90ES	3600	1700	600	630	4750	1465	1300	1550	1200	1100
HMG-160ES	4600	2300	0	730	5500	1880	1620	1650	1600	1400
HMG-200ES	5400	2500	0	790	6000	2280	1820	1850	2000	1600
HMG-300ES	6800	3100	0	930	7300	2890	2300	2200	2500	2000
HMG-350ES	7600	3200	0	980	7850	3370	2280	2250	3000	2000
HMG-400ES3121	8000	3400	0	1080	8600	3470	2400	2300	3100	2100
HMG-400ES3525	8900	3800	0	1130	9400	3900	2800	2900	3500	2500
HMG-500ES4025	9900	3800	0	1130	9600	4400	2800	2900	4000	2500
HMG-500ES4030	9900	4300	0	1130	10400	4400	3300	3400	4000	3000
HMG-600ES4030	9900	4300	0	1130	10400	4400	3300	3400	4000	3000

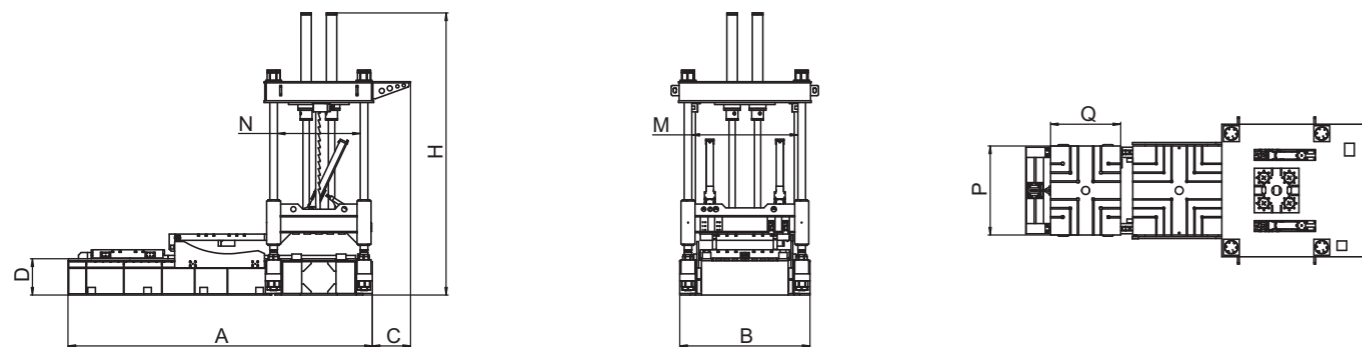

One way Machine	A	B	C	D	H	M	N	P	Q
HMG-90ES	4800	2000	600	630	4750	1465	1300	1200	1100
HMG-160ES	6000	2650	0	730	5500	1880	1620	1600	1400
HMG-200ES	6600	2950	0	790	6000	2280	1820	2000	1600
HMG-300ES	8100	3600	0	930	7300	2890	2300	2500	2000
HMG-350ES	8100	4200	0	980	7450	3370	2280	3000	2000
HMG-400ES3121	8500	4300	0	1080	8650	3470	2400	3100	2100
HMG-400ES3525	10100	4900	0	1130	9400	3900	2800	3500	2500
HMG-500ES4525	10100	4900	0	1130	9600	4400	2800	4000	2500
HMG-500ES4030	11600	5400	0	1130	10400	4400	3300	4000	3000
HMG-600ES4030	11600	5400	0	1130	10400	4400	3300	4000	3000

**Die Spotting press is the most sure & safe way to check the butting of core & cavity of Die & Mould.**

It allows you to conveniently match all the parts of the mould in more comfortable position. Check and finish the die at one place in more ergonomic position.

**The Advancements and Advantages**

High standard of configuration ensures the excellent performance of press, and all the main components for mechanical processing are manufactured by imported machining center, to ensure machining precision of press elements. The shift-out rail of lower mold plate adopts wear resistant rail with intensified handle and large-scale dust-proof device; Hydraulic system adopts optimal combination of imported high performance hydraulic elements, and oil pump hydraulic valve is the world first-class brand.

- CE Marked product with Certificate of Conformity
- Using high tensile rod to provide higher accuracy and to make more convenient for platen parallelism adjustment when the mold is closed with high pressure.
- Achieving digital PLC controlled by computer, all of the parameters can be displayed by the Siemens touch screen and free to set up. S7-1200 Version with Encoders as a standard component for ESA Series.
- Four Encoders with optional function to measure parallelism real time and protect mold during the clamping period.
- Sufficient Safety Devices and Pneumatic-mechanical locks for upper table.
- Using four mold clamping cylinders to make stress even when the mold is closed with high pressure.
- Using quick cylinder device, it speeds up null stroke without mold closing, and it makes lower energy consumption and more energy conservation.
- Using Anti-dropping, safety devices with suspension type to make your mold and machine safer.
- Using Oil-free self-lubrication, it makes the machine cleaner and more environmentally friendly.
- Providing practical reliable failure detection and alarm and low-pressure mold protection functions.

**WHY DIE SPOTTING PRESS:**

- No more dangerous die / mould handling by means of cranes, forklift trucks or lifting equipment.
- No more spotting on injection moulding machines, which are cost-intensive and difficult to access.
- Optimal accessibility and ergonomics by means of swivelling and tilting plates.
- Low operating and maintenance costs.
- High Flexibility.
- Considerable reduction of correction grinding through reproducibility





## New for ES Series:

### Siemens System: NEW for ES

SXXH was the first die spotting press manufacturer to use Siemens System in the Asia.

We use new S7-1200 Version as the standard configuration of the Press. New version replaces the old micro PLC S7-200 Smart.

With the new PLC:

- Remote Control module is optional
- Control and monitor press.
- All the parameters can be settled and saved
- Memory function-Mold database.
- A wide variety of signal modules for input and output as well as technology modules for special technological functions, such as counting, and communications modules are available both centrally or decentrally.
- The SIMATIC S7-1200 is approved for protection class Ip20

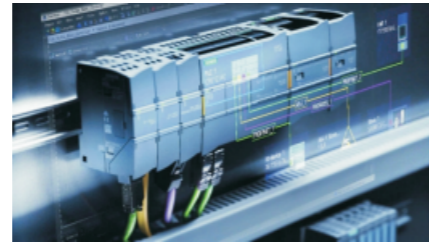

### Servo System

Servo System provide more economy way to operate Spotting press, and provide much better accuracy.

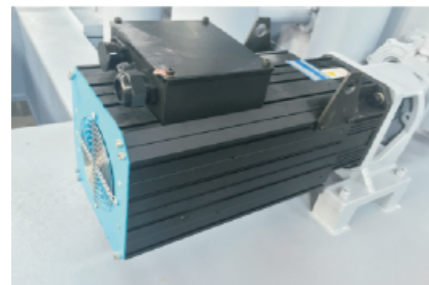

### Pneumatic-mechanical locks for moving base

Two Safety locks ensure the upper platen can be locked at any position when upper platen goes up or down. This Device is mandatory by EC rules.

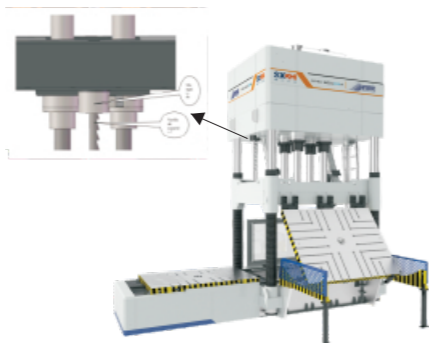

### Dynamic Checking device for Ejector.

It can be used to check whether the mould spring tips work normally or not.

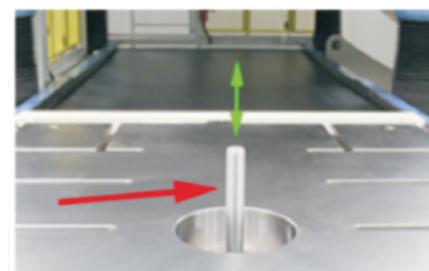

### Electronic Moving Base parallelism checking system(Optional)

There are four encoders at each corners of the moving base. The PLC screen shows the state of these four encoders working continuously. This means the parallelism between two platens can be monitored continuously. During the mold protection function, when the difference is more than the set tolerance, the machine will stop immediately. In other words, this function protects the mold from damage, when the worker leaves the tool between cavity and core of mold.

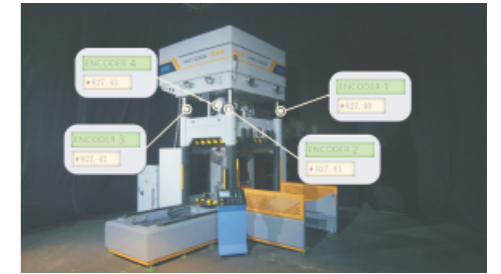

### Hydraulic Slides testing

Extra hydraulic power units could detect whether mould core-pulling unit and sliding block unit work normal or not at the same time of die assemble and mould repairing. The group of core-pulling can be decided by customs.



### QDC system-Optional

We will provide additional two way to reduce Mold Clamping time:

1. Electricity permanent Magnetic working table
2. Hydraulic clampers



### Wax Injection Testing device (Optional)

Provide Wax testing before Mold move to production machine.

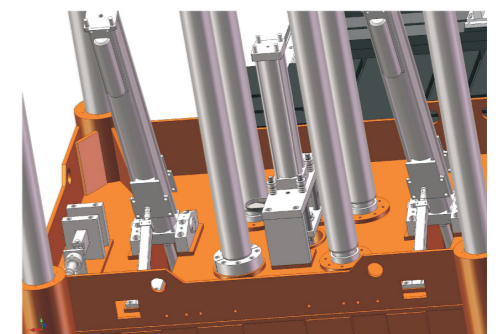







# Accessory Machine- Mold Flipper 90

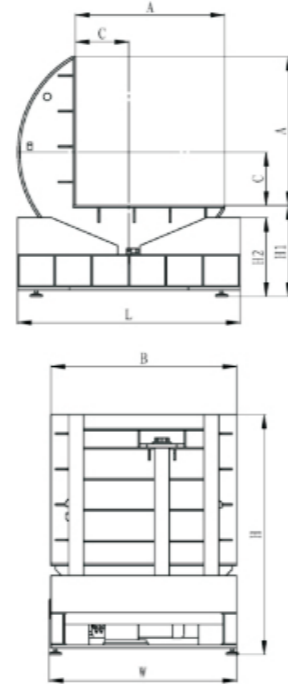
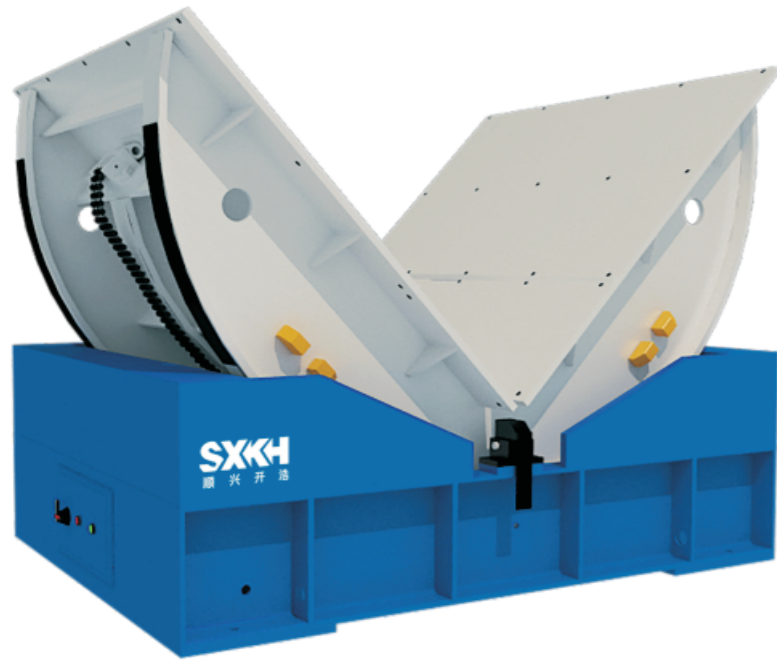

Electrical Motor Driven  
Economical and free Maintenance  
Save time, Manpower and operator's fatigue

- Optional 1: yellow bar
- Optional 2: Forklift Groove
- Optional 3: Hook
- Optional 4: Tapped Hole

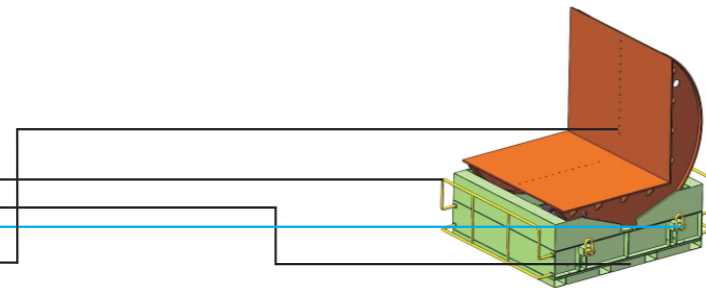

Model	SXKH-5T	SXKH-10T	SXKH-15T	SXKH-20T	SXKH-30T	SXKH-50T
Overturn Capacity (KN)	50	100	150	200	300	500
Table Height H1(mm)	605	730	730	860	985	985
Table Size AxB ( mm )	1100x1250	1300x1400	1500x1650	1600x2000	1800x2200	2010x2500
Motor Power	1.5KW	3KW	4KW	5.5KW	11KW	15KW
Center Size C	410	495	495	610	670	670
Max Machine Size LxWxH	1750x1250 x1800	1900x1450 x2150	1950x1650 x2350	2300x2050 x2600	2650x2250 x2900	2650x2250 x3100
Weight of Machine (KG)	1,600	2,500	2,800	5,200	9,000	12,000

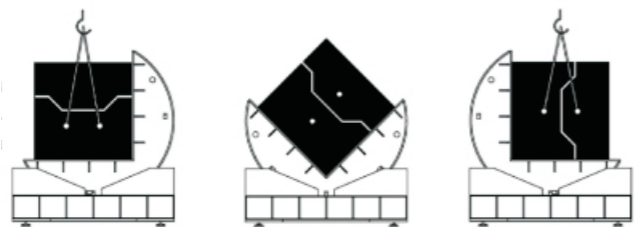

# Accessory Machine- Mold Flipper 180

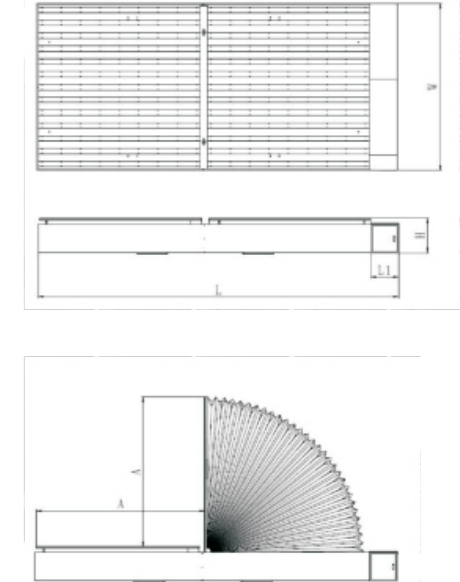

- Hydraulic cylinder driven, very safe to flip the mould by 90 degree
- Saves time, manpower and Operator's fatigue
- The tables can rest at 180 degree
- Does not require any dedicated space to keep the machine as the complete Hydraulic system can be accommodated in pit and the mould maintenance can be done while the mould is kept on the table.

Model	PFM-5T	PFM-10T	PFM-15T	PFM-20T	PFM-30T	PFM-50T
Weight of Machine (KG)	50	100	150	200	300	500
L(mm)	2800	3100	3600	3800	4200	6000
L1(mm)	400	400	500	500	500	700
H(mm)	350	450	450	530	530	630
W(min)	1250	1400	1650	2000	2200	3000
A(mm)	1100	1300	1500	1600	1800	2600
Power(KW)	1.5	3	4	5.5	11	18
Weight of Machine (KG)	4,000	4,500	5,000	10,000	15,000	19,000

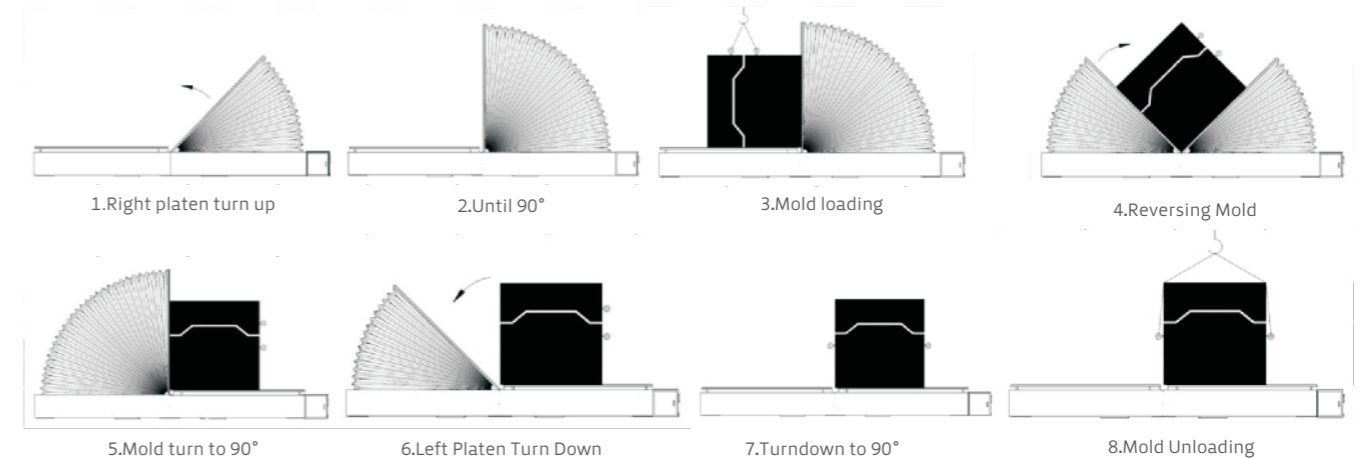

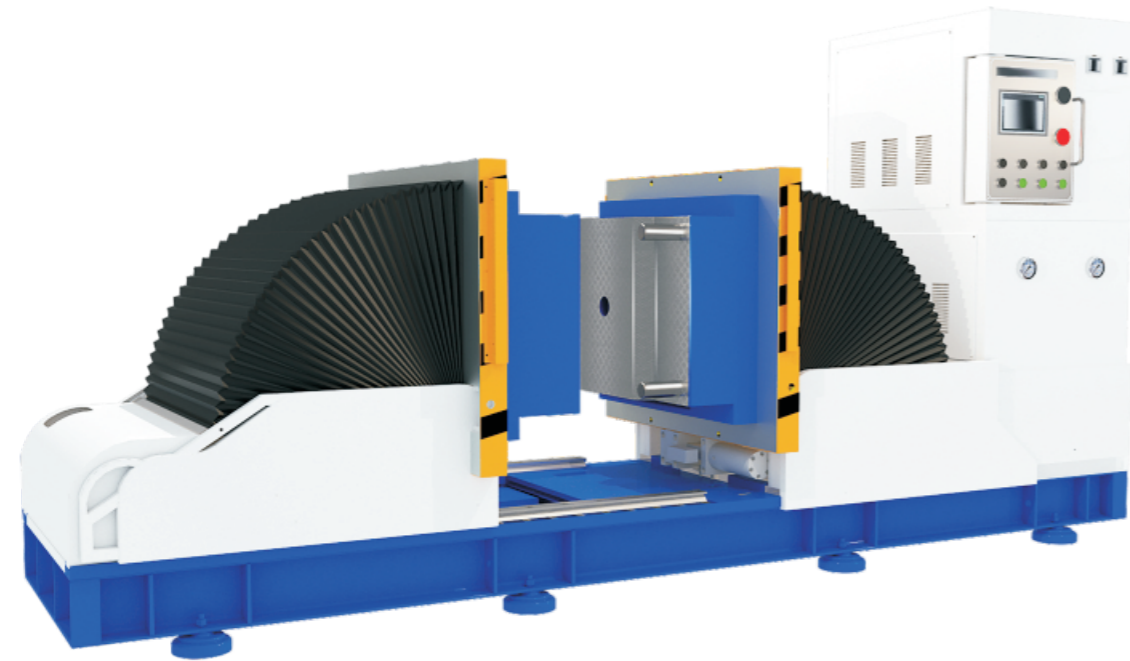

- The inspection machine can be equipped with a quick die change system on both platen, in order to improve the efficiency of mold loading and unloading.
- Mold can be tilted by 90 degrees and do mold maintenance.
- Mold hydraulic system testing
- Mold Ejector testing
- Mold Water cooling system testing
- Siemens PLC control system

ITEM	UNIT	TMG1008	TMG1518	TMG2120
Clamping Force	KN	55	100	100
Opening Force	KN	50	60	80
Platen A Ejector Force	KN	110	110	110
Platen Dimension	mm	1000×800	1500×1800	2100×2000
Overturn Degree	°	0-90°(option)	0-90°(option)	0-90°(option)
Max. Opening Stroke	mm	700	2000	3000
Min. Opening Stroke	mm	120	400	500
Die Open/Close Speed	mm/s	0-40	0-40	0-40
Overturn Speed	°/s	8	8	8
Max. Weight of Mold	Kg	8,000	18,000	25,000
Max. Overturn Capacity	Kn	40	90	130
Machine Weight	Kg	3,100	12,000	30,000
External Dimension LWH	mm	3400X880X1680	6000X2360X2150	7200*2400*2200

## China

FAW First Auto Works	HMG-600JM4025 HMG-500JM3121	Ningbo Sindar Mold	HMG-400JM3020 HMG-160JM1613
Basis	HMG-500JM3121 HMG-70JM1008 HMG-400JM3020	Ningbo Huiwang Mold	HMG-400JM3020 HMG-528JM3525 HMG-160JM1613
Joyson Electronics	HMG-70JM	Changzhou Huawei Mold	HMG-500JM3121
Hisense Mold- Qingdao	HMG-300JM2218	Great Wall	HMG-400JM3020 HMG-300JM2218 HMG-400JM3020
Lexy Kingclean	HMG-200JM1815*2 HMG-100JM1411*2	BICOM Optics	HMG-200JM1815*2 HMG-300JM2218*2
Toyoto Changshu	HMG-100JM1411	Ljunghall Wuxi	HMG-200JM1815
Chongqing Guangneng	HMG-500JM3121 HMG-400JM3020 HMG-300B2218 HMG-200B1815	Shenzhen-Jason Tooling	HMG-400JM3020 HMG-300JM2218 HMG-200JM1815*2 HMG-120JM1411*2
Ningbo Morden Mold	HMG-350JM2820	Xiangshan Tong-Jia Mold	HMG-500JM3121
Chongqing Landai Power	HMG-500JM3121	Shanghai YADELIN	HMG-400JM3020

## Europe

Portugal-Somema Lda	HMG-400JM3020	Spain-Matrigalasa	HMG-400ES3020
Portugal-Somema Lda	HMG-300JM2218	Spain-Euroutil S.A	HMG-350ES2820
Germany- Hisense Mold	HMG-400JM3020	Spain-Matinerea Honsel	HMG-400ES4030
Turkey-Ata Kalip	HMG-100JM1411	Britain-SET Europe Ltd	Mold flipper FMG-30
Germany-IDEAL Automotive	HMG-350JM2820	Germany-Bock	Mold flipper FMG-15
Czech Rublic- Letoplast	Mold flipperFMG-30	Czech Rublic- Letoplast	Die mold inspection machine

## North & South American

Mexico-Matinerea Honsel	HMG-400JM4030	Argentina-Jose M. Alladioe S.A	HMG-280JM2015
Mexico-Rongtai Group	HMG-400JM3020	Mexico- Aurrenak Service S.A De C.V	HMG-600JM3525
United Too and Mold	HMG-500ES3121	United Too and Mold	HMG-200ES1815

## India

Bharat Techbnoplast Pvt Ltd	HMG-160JM1613	JSG Innotech Pvt. Ltd	HMG-100JM1411
Nilkamal Ltd	HMG-200JM1815 HMG-160JM1613 Hyd. Press 250T	CTM Samvardhana Motherson	HMG-350JM2820 HMG-350JM2020
JSG INNOTECH PVT. LTD	HMG-100JM1411	Takahata	Mold Flipper FMG-5T
Marvel Technology&Tools.	HMG-160JM1613	Precitech Industries	HMG-120JM1411
Premier Indoplast PVT LTD	HMG-120JM1411	Savitri Automation	HMG-200JM1815

## Others countries

Thailand: Hatari Electric Co.,Ltd	HMG-70JM1008	Thailand: Power Mold Factory Co.,Ltd	HMG-300A2218
Vietnam -TIEN PHONG PLASTIC JOIN STOCK COMPANY	HMG-200JM1815 HMG-100JM1411	Malaysia-ABTechnology	Mold flipper FMG-5T



**Machining Center**



**Full automatic loading testing**



**Press Inspection**



**Transport**



Domestic China Land transport



Oversea Shipping

