

本公司保留修改技术参数的权利，恕不另行通知。 We reserve the right to change specifications without prior notice.

精密 **高效** **节能** **环保** **智能**
PRECISION EFFICIENCY ENERGY-SAVING ECO-FRIENDLY INTELLIGENCE



NINGBO TSUENSAINT TECHNOLOGY DEVELOPMENT CO.,LTD.
宁波荃笙科技发展有限公司

Add: Building 4, No.128, Jingyuan Road, High Tech Zone, Ningbo, Zhejiang.
地址: 浙江省宁波高新区晶源路128号4号楼

Mob: 0086-15658273134 0086-13967807575

Email: michelle@tsuensaint.com info@tsuensaint.com

TSUENSAINT 2023



全电动精密注塑成型机
ALL ELECTRIC INJECTION MOLDING MACHINE

机器性能 Intro

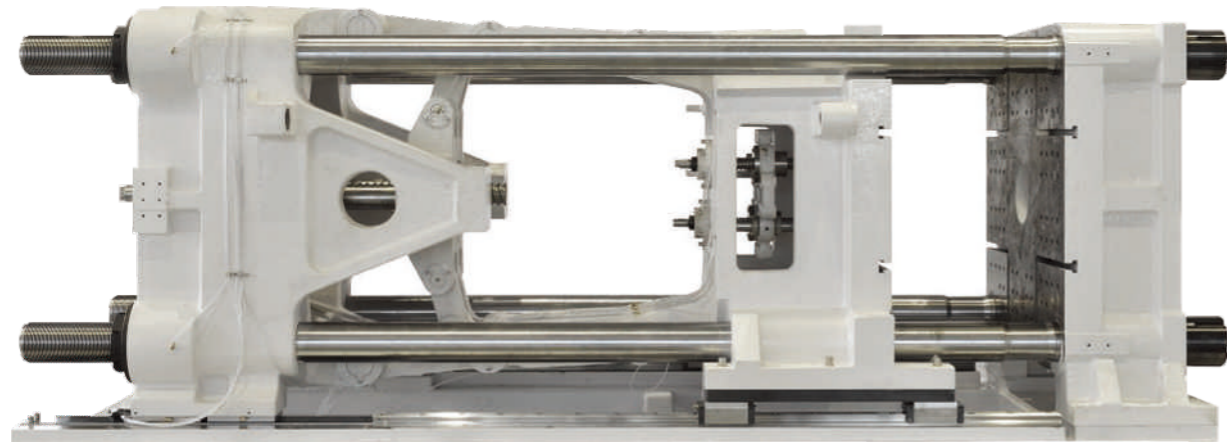

高刚性自锁式五点曲肘合模结构，响应速度快，开关模动作平滑、敏捷、高压锁模后机构自锁，延长锁模丝杆和模具使用寿命。

High rigid toggle structure with 5 pins and self-lock, fast response speed, lead to smooth mold open/close, structure self-lock after high-pressure clamping, lengthen the service life of clamping ball screw and mold.



专用全电动注塑成型机电控器具有友好的人机界面和精确快速的过程控制，操作简单、功能强大

Professional controller for all electric injection molding machine has friendship human-computer interface, rapid and accuracy process control, easy operate, powerful function



各种波形显示和检测，先进的生产管理和工艺控制

All kind of curves display and inspection, modern production management and technology control



紧凑坚实的机身设计，具有床身精度高、对模具损耗小的特点，模块安全继电器，动作安全稳定

Compact and robust machine bed is high precision and minimum wear and tear on the mold. Safety relay of mold maintains the stability and security of motion



高效率润滑设计，采用石墨合金钢套（铜套）提升润滑效果，减少润滑油使用量使机器更加清洁耐用

High efficiency lubrication system, use the graphite alloy steel sleeve (copper sleeve), reduce oil usage and make machine more clean and durable



机器性能 Intro

无阻力合模导向结构，线性导轨支撑导向结构，高耐磨，低摩擦，运行更平稳。优化动模板结构，拉杆脱离，无需润滑，具有高刚性，高强度，充分保证了模板的平行度和精度。

Zero-resistance clamping injection guider structure, heavy loaded guider device supported by linear track, better wear resistance, lower friction and more smooth operation. Optimize mold structure, tie bar no touch with moving platen, no lubrication. The system has high rigidity and strength, guarantee the accuracy of platen parallel excellently.

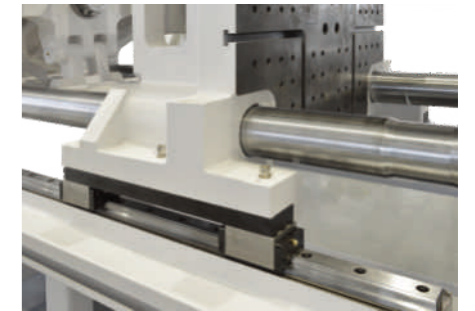

T型槽+螺丝固定模板加嵌入式模具定位圈，高标准锁模，降低模具损耗，装模便捷，组装方便。

T-slot & screw fixation platen embedded mold locating ring design, high-standard clamping system reduces mold loss and makes more easy mold installation.

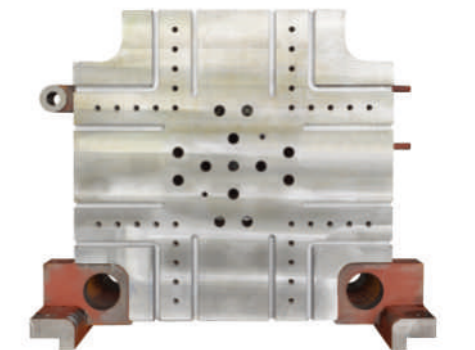

开模反应快、稳，扭矩大，阻力小。合模伺服电机皮带连接驱动滚珠丝杠，灵活度高，维护简单；高品质皮带，保固10年；特优转轮，惯性小。

Fast and smooth mold movement, high torque, less resistance. Clamping servo motor connects ball screw, flexible operation and simply maintenance. High-quality belt, warranty 10 years; superior rotating wheel, low inertia.

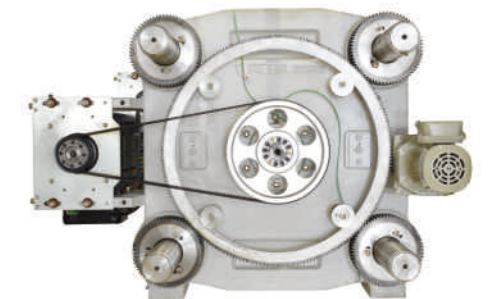

高速响应的伺服电机和高扭矩的滚珠丝杠是全电动注塑机的核心，源自日本技术，保证了机器的国际领先性，开合模控制更精准。

Top responsibility servo motor and high torque ball screw is key element, origin Japan technology to keep advantage leading in the word, precise for mold movement.

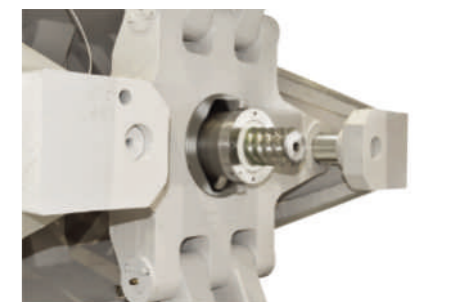

参数表 PARAMETERS

| 型号 | MODEL | SE-400V | |
|-------------|------------------------|---------|---------|
| 锁模力 | CLAMP TONNAGE | kN | 400 |
| 拉杆内间距 (HXV) | SPACE BETWEEN TIE-BARS | mm | 304x284 |
| 模板尺寸 (HXV) | PLATEN DIMENSION | mm | 450x430 |
| 移模行程 | OPEN STROKE | mm | 230 |
| 模厚 | MOULD THICKNESS | mm | 120-350 |
| 顶出行程 | EJECTOR STROKE | mm | 60 |
| 顶出力 | EJECTOR FORCE | kN | 27 |
| 顶出杆数 | EJECTOR NUMBER | | 1 |
| 机器重量 | MACHINE WEIGHT | T | 2.3 |

| | | | | | | | | |
|-----------|----------------------------|-----------------|------|----|----|------|----|----|
| 螺杆直径 | SCREW DIAMETER | mm | 18 | 20 | 22 | 22 | 25 | 28 |
| 注射容量 | INJECTION CAPACITY | cm ³ | 19 | 24 | 29 | 40 | 52 | 65 |
| 注射质量 (PS) | INJECTION WEIGHT (PS) | g | 17 | 21 | 26 | 36 | 47 | 59 |
| 塑化能力 (PS) | PLASTICIZING CAPACITY (PS) | kg/h | 12.5 | 15 | 18 | 18 | 25 | 35 |
| 螺杆转速 | SCREW SPEED | rpm | 400 | | | 400 | | |
| 温控段数 | HEATER BAND | | 3+1 | | | 3+1 | | |
| 加热功率 | HEATER POWER | kW | 2.6 | | | 4.2 | | |
| 喷嘴接触力 | NOZZLE PRESSING FORCE | kN | 15.7 | | | 15.7 | | |

| 标准注射单元 (STANDARD) | | 60 | | 130 | | | | |
|-------------------|-----------------------------|---------------------|------|------|------|------|------|------|
| 注射速度 | INJECTION SPEED | mm / s | 200 | | 200 | | | |
| 注射速率 (PS) | INJECTION RATE (PS) | cm ³ /s | 58 | 72 | 88 | 76 | 98 | 123 |
| 注射压力 | INJECTION PRESSURE | MPa | 303 | 245 | 203 | 292 | 240 | 188 |
| | | kgf/cm ² | 3086 | 2500 | 2066 | 2978 | 2448 | 1918 |
| 最大保压力 | MAX.INJECTION HOLD PRESSURE | MPa | 242 | 196 | 162 | 233 | 192 | 156 |
| | | kgf/cm ² | 2469 | 2000 | 1653 | 2382 | 1958 | 1594 |
| 总功率 | TOTAL POWER | kW | 10.6 | | | 16.8 | | |

| 选配注射单元 (OPTION) | | 60H | | 130H | | | | |
|-----------------|-----------------------------|---------------------|------|------|------|------|------|------|
| 注射速度 | INJECTION SPEED | mm / s | 450 | | 400 | | | |
| 注射速率 (PS) | INJECTION RATE (PS) | cm ³ /s | 117 | 145 | 175 | 152 | 197 | 247 |
| 注射压力 | INJECTION PRESSURE | MPa | 303 | 245 | 203 | 317 | 245 | 195 |
| | | kgf/cm ² | 3086 | 2500 | 2066 | 3228 | 2500 | 1993 |
| 最大保压力 | MAX.INJECTION HOLD PRESSURE | MPa | 242 | 196 | 162 | 253 | 196 | 156 |
| | | kgf/cm ² | 2469 | 2000 | 1653 | 2583 | 2000 | 1594 |
| 总功率 | TOTAL POWER | kW | 17.6 | | | 19.8 | | |

机器外形尺寸图 OVERALL DIMENSIONS

单位: mm

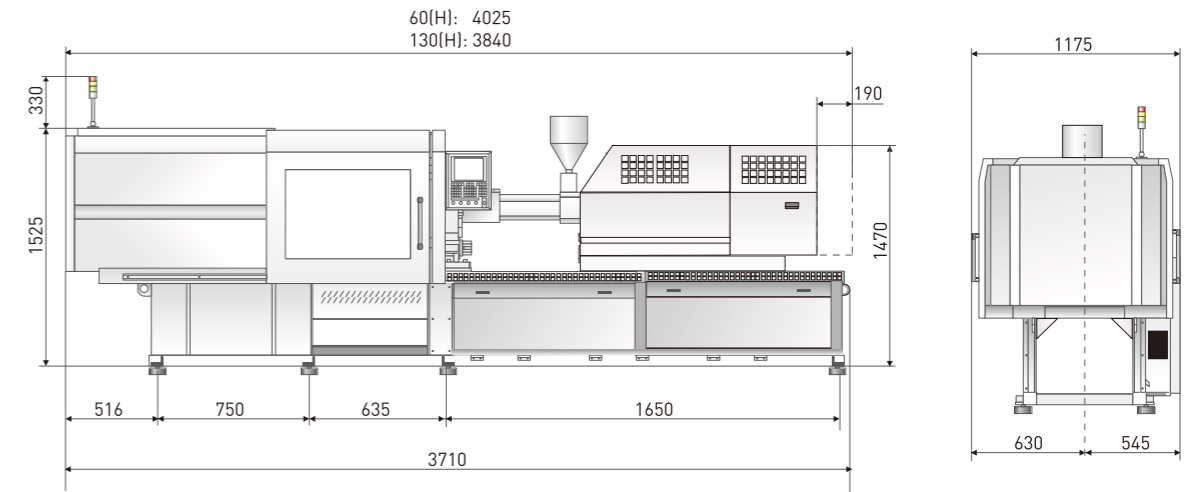

模板尺寸图 PLATEN DIMENSIONS

单位: mm

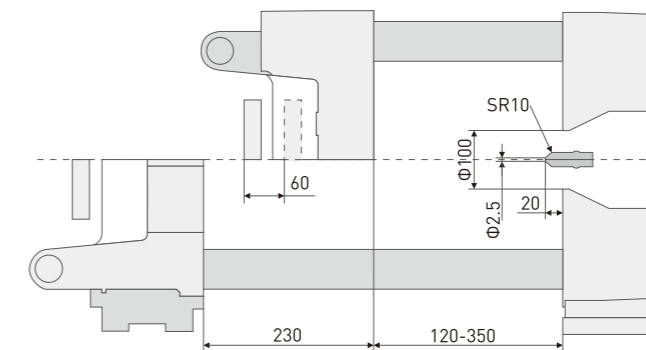
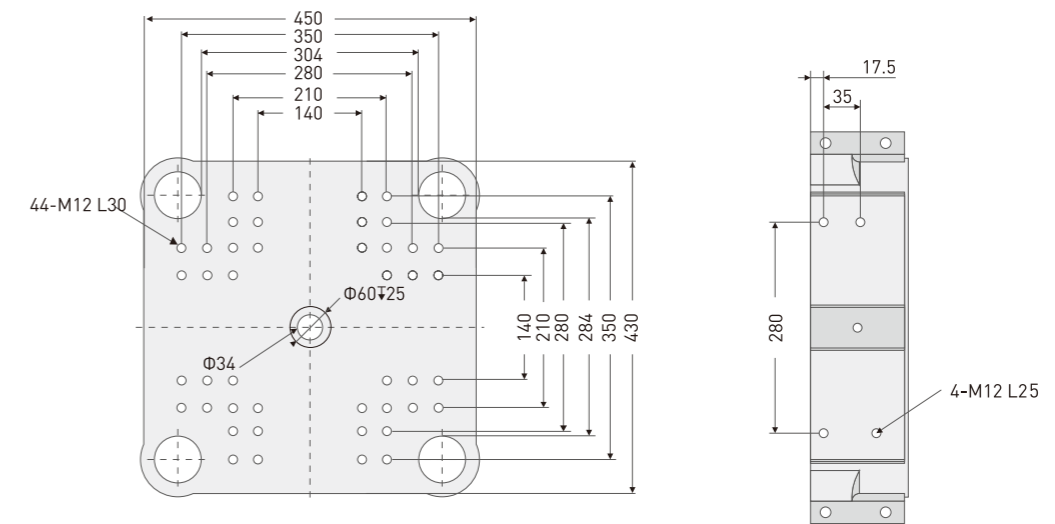

参数表 PARAMETERS

| 型号 | MODEL | SE-600V | |
|-------------|------------------------|---------|---------|
| 锁模力 | CLAMP TONNAGE | kN | 600 |
| 拉杆内间距 (HXV) | SPACE BETWEEN TIE-BARS | mm | 365x325 |
| 模板尺寸 (HXV) | PLATEN DIMENSION | mm | 520x480 |
| 移模行程 | OPEN STROKE | mm | 270 |
| 模厚 | MOULD THICKNESS | mm | 120-380 |
| 顶出行程 | EJECTOR STROKE | mm | 60 |
| 顶出力 | EJECTOR FORCE | kN | 27 |
| 顶出杆数 | EJECTOR NUMBER | | 5 |
| 机器重量 | MACHINE WEIGHT | T | 3.2 |

| | | | | | | | | | | | |
|-----------|----------------------------|-----------------|------|----|----|------|----|----|------|----|-----|
| 螺杆直径 | SCREW DIAMETER | mm | 18 | 20 | 22 | 22 | 25 | 28 | 25 | 28 | 32 |
| 注射容量 | INJECTION CAPACITY | cm ³ | 19 | 24 | 29 | 40 | 52 | 65 | 64 | 80 | 105 |
| 注射质量 (PS) | INJECTION WEIGHT (PS) | g | 17 | 21 | 26 | 36 | 47 | 59 | 58 | 73 | 95 |
| 塑化能力 (PS) | PLASTICIZING CAPACITY (PS) | kg/h | 12.5 | 15 | 18 | 18 | 25 | 35 | 25 | 35 | 48 |
| 螺杆转速 | SCREW SPEED | rpm | 400 | | | 400 | | | 400 | | |
| 温控段数 | HEATER BAND | | 3+1 | | | 3+1 | | | 3+1 | | |
| 加热功率 | HEATER POWER | kW | 2.6 | | | 4.8 | | | 5.6 | | |
| 喷嘴接触力 | NOZZLE PRESSING FORCE | kN | 15.7 | | | 15.7 | | | 19.6 | | |

| 标准注射单元 (STANDARD) | | 60 | | | 130 | | | 165 | | | |
|-------------------|-----------------------------|---------------------|------|------|------|------|------|------|------|------|------|
| 注射速度 | INJECTION SPEED | mm / s | 200 | | | 200 | | | 200 | | |
| 注射速率 (PS) | INJECTION RATE (PS) | cm ³ / s | 58 | 72 | 88 | 76 | 98 | 123 | 98 | 123 | 161 |
| 注射压力 | INJECTION PRESSURE | Mpa | 303 | 245 | 203 | 292 | 240 | 188 | 272 | 217 | 180 |
| | | kgf/cm ² | 3086 | 2500 | 2066 | 2978 | 2448 | 1918 | 2774 | 2214 | 1836 |
| 最大保压力 | MAX.INJECTION HOLD PRESSURE | Mpa | 242 | 196 | 162 | 233 | 192 | 156 | 217 | 176 | 144 |
| | | kgf/cm ² | 2469 | 2000 | 1653 | 2382 | 1958 | 1594 | 2220 | 1795 | 1468 |
| 总功率 | TOTAL POWER | kW | | | | | | | | | |

| 选配注射单元 (OPTION) | | 60H | | | 130H | | | 165H | | | |
|-----------------|-----------------------------|---------------------|------|------|------|------|------|------|------|------|------|
| 注射速度 | INJECTION SPEED | mm / s | 450 | | | 400 | | | 400 | | |
| 注射速率 (PS) | INJECTION RATE (PS) | cm ³ / s | 117 | 145 | 175 | 152 | 197 | 247 | 196 | 246 | 322 |
| 注射压力 | INJECTION PRESSURE | Mpa | 303 | 245 | 203 | 317 | 245 | 195 | 276 | 220 | 168 |
| | | kgf/cm ² | 3086 | 2500 | 2066 | 3228 | 2500 | 1993 | 2815 | 2244 | 1718 |
| 最大保压力 | MAX.INJECTION HOLD PRESSURE | Mpa | 242 | 196 | 162 | 253 | 196 | 156 | 221 | 176 | 135 |
| | | kgf/cm ² | 2469 | 2000 | 1653 | 2583 | 2000 | 1594 | 2252 | 1795 | 1374 |
| 总功率 | TOTAL POWER | kW | 17.6 | | | 19.8 | | | 28.8 | | |

本公司保留修改技术参数的权利，恕不另行通知。 We reserve the right to change specifications without prior notice.

机器外形尺寸图 OVERALL DIMENSIONS

单位: mm

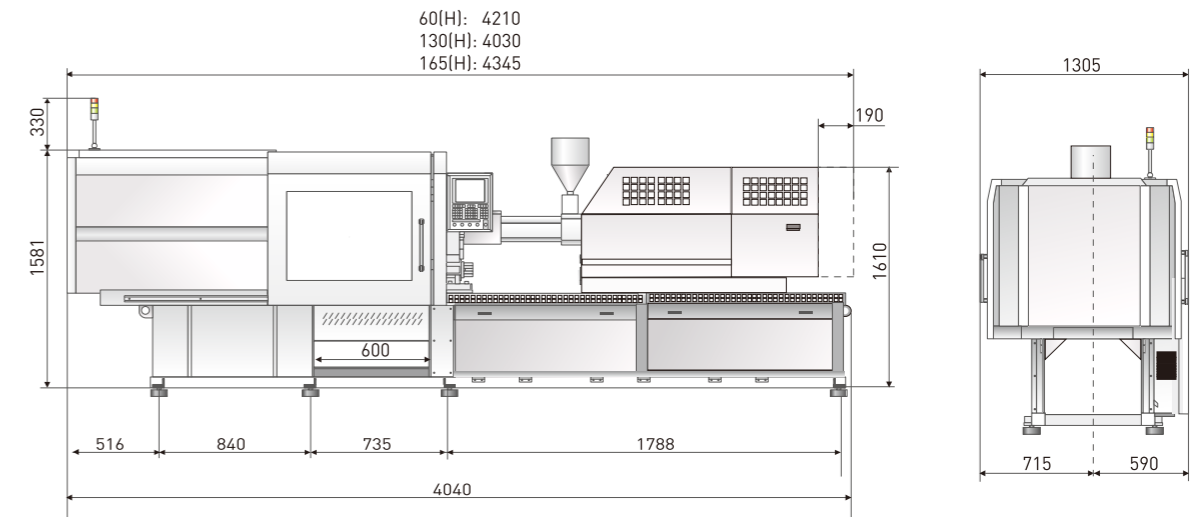

模板尺寸图 PLATEN DIMENSIONS

单位: mm

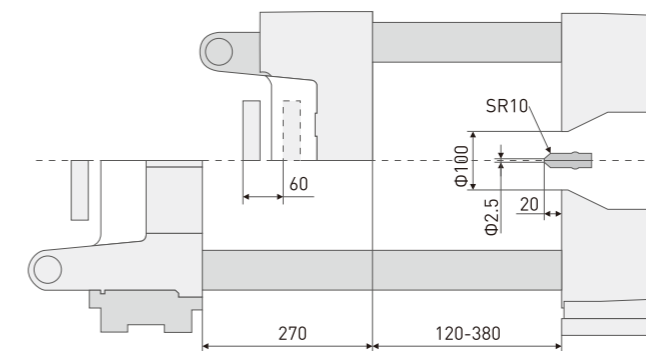
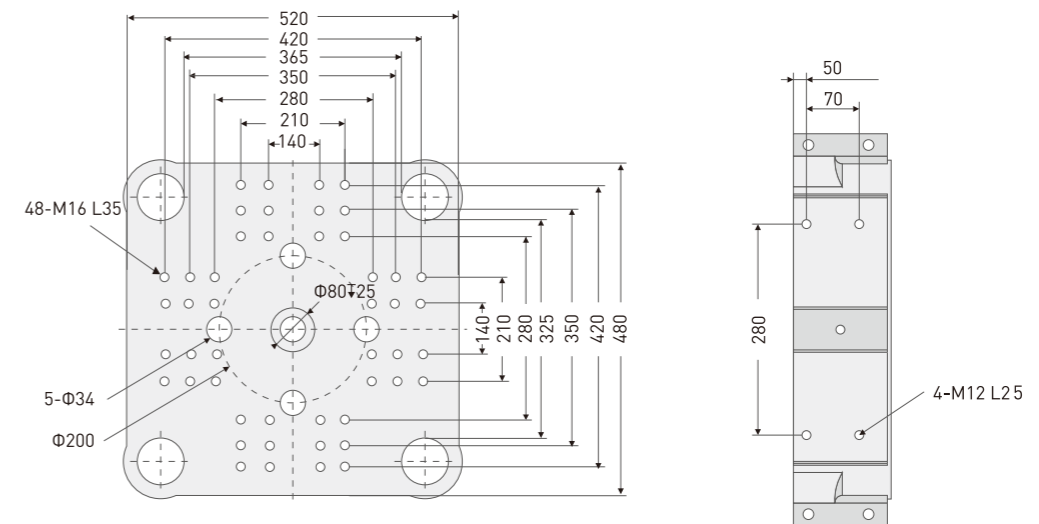

参数表 PARAMETERS

| 型号 | MODEL | SE-900V | |
|-------------|------------------------|---------|---------|
| 锁模力 | CLAMP TONNAGE | kN | 900 |
| 拉杆内间距 (HXV) | SPACE BETWEEN TIE-BARS | mm | 420x370 |
| 模板尺寸 (HXV) | PLATEN DIMENSION | mm | 620x580 |
| 移模行程 | OPEN STROKE | mm | 320 |
| 模厚 | MOULD THICKNESS | mm | 150-420 |
| 顶出行程 | EJECTOR STROKE | mm | 100 |
| 顶出力 | EJECTOR FORCE | kN | 32 |
| 顶出杆数 | EJECTOR NUMBER | | 5 |
| 机器重量 | MACHINE WEIGHT | T | 4.3 |

| | | | | | | | | | | | |
|-----------|----------------------------|-----------------|------|----|----|------|----|-----|------|-----|-----|
| 螺杆直径 | SCREW DIAMETER | mm | 22 | 25 | 28 | 25 | 28 | 32 | 30 | 34 | 38 |
| 注射容量 | INJECTION CAPACITY | cm ³ | 40 | 52 | 65 | 64 | 80 | 105 | 92 | 118 | 147 |
| 注射质量 (PS) | INJECTION WEIGHT (PS) | g | 36 | 47 | 59 | 58 | 73 | 95 | 84 | 107 | 134 |
| 塑化能力 (PS) | PLASTICIZING CAPACITY (PS) | kg/h | 18 | 25 | 35 | 25 | 35 | 48 | 42 | 161 | 82 |
| 螺杆转速 | SCREW SPEED | rpm | 400 | | | 400 | | | 400 | | |
| 温控段数 | HEATER BAND | | 3+1 | | | 3+1 | | | 3+1 | | |
| 加热功率 | HEATER POWER | kW | 4.8 | | | 5.6 | | | 7.8 | | |
| 喷嘴接触力 | NOZZLE PRESSING FORCE | kN | 15.7 | | | 19.6 | | | 19.6 | | |

| 标准注射单元 (STANDARD) | | | 130 | 165 | 240 | | | | | | |
|-------------------|-----------------------------|---------------------|------|------|------|------|------|------|------|------|------|
| 注射速度 | INJECTION SPEED | mm / s | 200 | | | | | | | | |
| 注射速率 (PS) | INJECTION RATE (PS) | cm ³ / s | 76 | 98 | 123 | 98 | 123 | 161 | 141 | 182 | 227 |
| 注射压力 | INJECTION PRESSURE | Mpa | 292 | 240 | 188 | 272 | 217 | 180 | 252 | 196 | 157 |
| | | kgf/cm ² | 2978 | 2448 | 1918 | 2774 | 2214 | 1836 | 2569 | 2000 | 1601 |
| 最大保压力 | MAX.INJECTION HOLD PRESSURE | Mpa | 233 | 192 | 156 | 217 | 176 | 144 | 202 | 157 | 126 |
| | | kgf/cm ² | 2382 | 1958 | 1594 | 2220 | 1795 | 1468 | 2055 | 1600 | 1281 |
| 总功率 | TOTAL POWER | kW | 16.8 | | | 20.6 | | | 28.2 | | |

| 选配注射单元 (OPTION) | | | 130H | 165H | 240H | | | | | | |
|-----------------|-----------------------------|---------------------|------|------|------|------|------|------|------|------|------|
| 注射速度 | INJECTION SPEED | mm / s | 400 | | | | | | | | |
| 注射速率 (PS) | INJECTION RATE (PS) | cm ³ / s | 152 | 197 | 247 | 196 | 246 | 322 | 247 | 318 | 397 |
| 注射压力 | INJECTION PRESSURE | Mpa | 317 | 245 | 195 | 276 | 220 | 168 | 252 | 196 | 157 |
| | | kgf/cm ² | 3228 | 2500 | 1993 | 2815 | 2244 | 1718 | 2569 | 2000 | 1601 |
| 最大保压力 | MAX.INJECTION HOLD PRESSURE | Mpa | 253 | 196 | 156 | 221 | 176 | 135 | 202 | 157 | 126 |
| | | kgf/cm ² | 2583 | 2000 | 1594 | 2252 | 1795 | 1374 | 2055 | 1600 | 1281 |
| 总功率 | TOTAL POWER | kW | 19.8 | | | 28.8 | | | 37.8 | | |

本公司保留修改技术参数的权利，恕不另行通知。 We reserve the right to change specifications without prior notice.

机器外形尺寸图 OVERALL DIMENSIONS

单位: mm

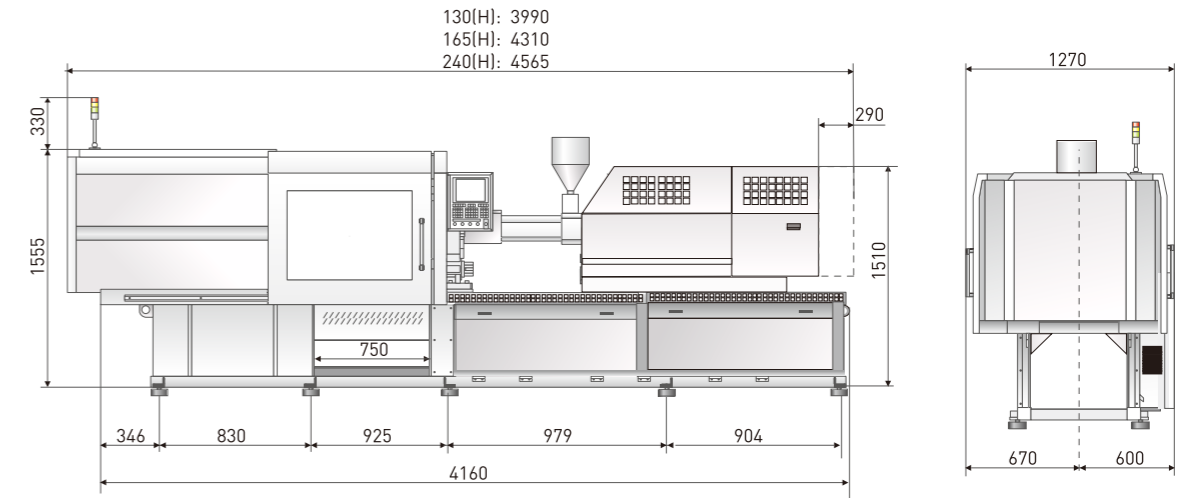

模板尺寸图 PLATEN DIMENSIONS

单位: mm

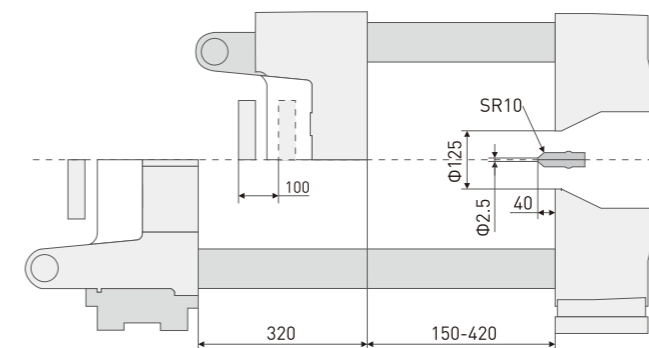
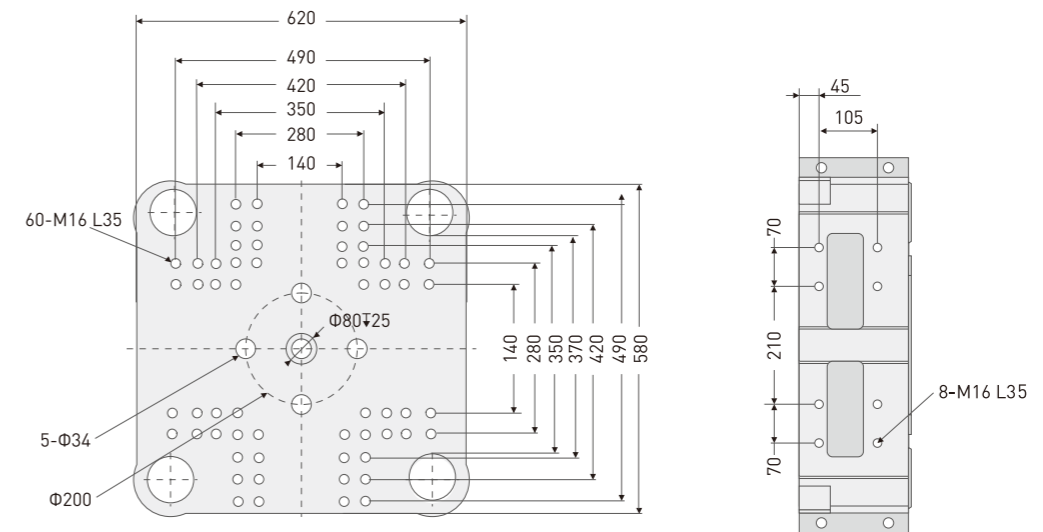

参数表 PARAMETERS

| 型号 | MODEL | SE-1200V | |
|-------------|------------------------|----------|---------|
| 锁模力 | CLAMP TONNAGE | kN | 1200 |
| 拉杆内间距 (HXV) | SPACE BETWEEN TIE-BARS | mm | 470x430 |
| 模板尺寸 (HXV) | PLATEN DIMENSION | mm | 690x650 |
| 移模行程 | OPEN STROKE | mm | 360 |
| 模厚 | MOULD THICKNESS | mm | 150-490 |
| 顶出行程 | EJECTOR STROKE | mm | 100 |
| 顶出力 | EJECTOR FORCE | kN | 32 |
| 顶出杆数 | EJECTOR NUMBER | | 5 |
| 机器重量 | MACHINE WEIGHT | T | 6 |

| 螺杆直径 | SCREW DIAMETER | mm | 25 | 28 | 32 | 30 | 34 | 38 | 36 | 40 | 45 |
|-----------|----------------------------|-----------------|-------|----|-----|------|-----|-----|-------|-------|-----|
| 注射容量 | INJECTION CAPACITY | cm ³ | 64 | 80 | 105 | 92 | 118 | 147 | 173 | 214 | 270 |
| 注射质量 (PS) | INJECTION WEIGHT (PS) | g | 58 | 73 | 95 | 84 | 107 | 134 | 157.5 | 194.4 | 246 |
| 塑化能力 (PS) | PLASTICIZING CAPACITY (PS) | kg/h | 25 | 35 | 48 | 42 | 61 | 82 | 71 | 91 | 123 |
| 螺杆转速 | SCREW SPEED | rpm | 400 | | | 400 | | | 350 | | |
| 温控段数 | HEATER BAND | | 3+1 | | | 3+1 | | | 3+1 | | |
| 加热功率 | HEATER POWER | kW | 5.6 | | | 7.8 | | | 10.3 | | |
| 喷嘴接触力 | NOZZLE PRESSING FORCE | kN | 19.61 | | | 19.6 | | | 29.4 | | |

| 标准注射单元 (STANDARD) | | | 165 | 240 | 450 | | | | | | |
|-------------------|-----------------------------|---------------------|------|------|------|------|------|------|------|------|------|
| 注射速度 | INJECTION SPEED | mm / s | 200 | 200 | 200 | | | | | | |
| 注射速率 (PS) | INJECTION RATE (PS) | cm ³ / s | 98 | 123 | 161 | 141 | 182 | 227 | 204 | 251 | 318 |
| 注射压力 | INJECTION PRESSURE | Mpa | 272 | 217 | 180 | 252 | 196 | 157 | 258 | 210 | 165 |
| | | kgf/cm ² | 2774 | 2214 | 1836 | 2569 | 2000 | 1601 | 2636 | 2135 | 1687 |
| 最大保压力 | MAX.INJECTION HOLD PRESSURE | Mpa | 217 | 176 | 144 | 202 | 157 | 126 | 207 | 167 | 132 |
| | | kgf/cm ² | 2220 | 1795 | 1468 | 2055 | 1600 | 1281 | 2109 | 1708 | 1345 |
| 总功率 | TOTAL POWER | kW | 20.6 | | 28.2 | | 40.3 | | | | |

| 选配注射单元 (OPTION) | | | 165H | 240H | 450H | | | | | | |
|-----------------|-----------------------------|---------------------|------|------|------|------|------|------|------|------|------|
| 注射速度 | INJECTION SPEED | mm / s | 400 | 350 | 350 | | | | | | |
| 注射速率 (PS) | INJECTION RATE (PS) | cm ³ / s | 196 | 246 | 322 | 247 | 318 | 397 | 357 | 440 | 557 |
| 注射压力 | INJECTION PRESSURE | Mpa | 276 | 220 | 168 | 252 | 196 | 157 | 258 | 210 | 165 |
| | | kgf/cm ² | 2815 | 2244 | 1718 | 2569 | 2000 | 1601 | 2636 | 2135 | 1687 |
| 最大保压力 | MAX.INJECTION HOLD PRESSURE | Mpa | 221 | 176 | 135 | 202 | 157 | 126 | 207 | 167 | 132 |
| | | kgf/cm ² | 2252 | 1795 | 1374 | 2055 | 1600 | 1281 | 2109 | 1708 | 1345 |
| 总功率 | TOTAL POWER | kW | 28.8 | | 37.8 | | 64.3 | | | | |

机器外形尺寸图 OVERALL DIMENSIONS

单位: mm

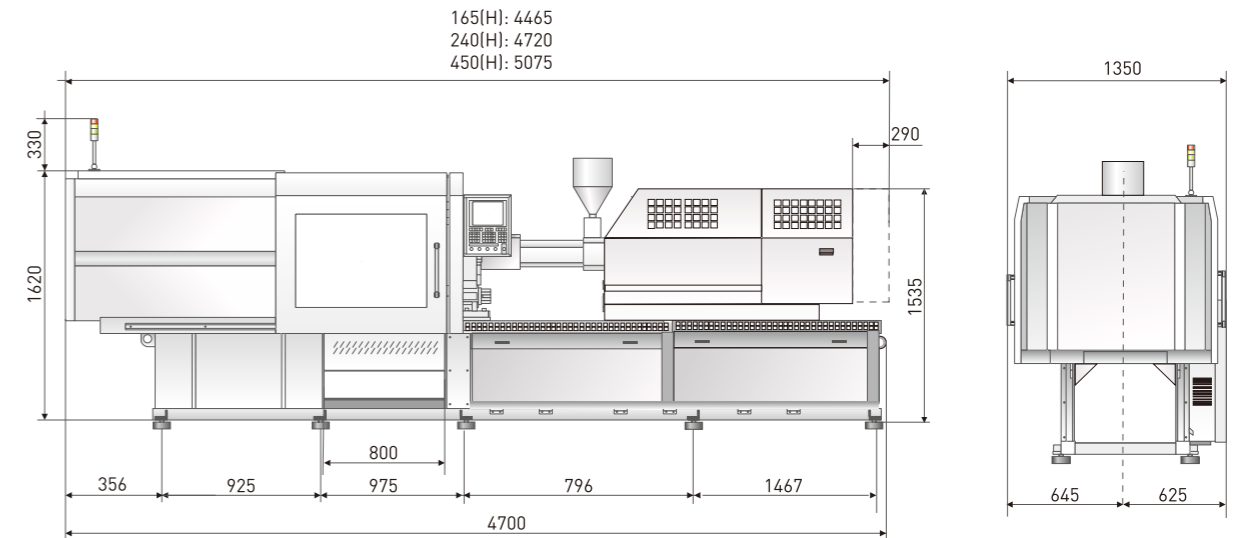

模板尺寸图 PLATEN DIMENSIONS

单位: mm

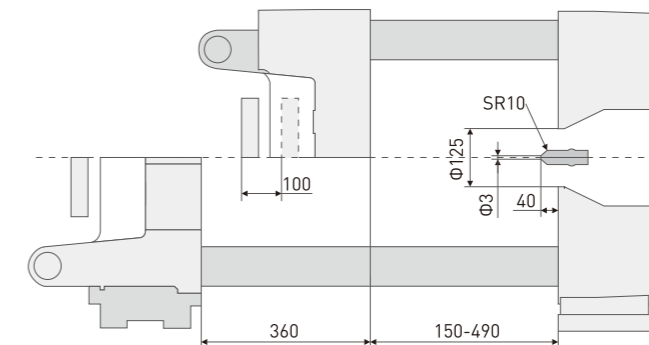
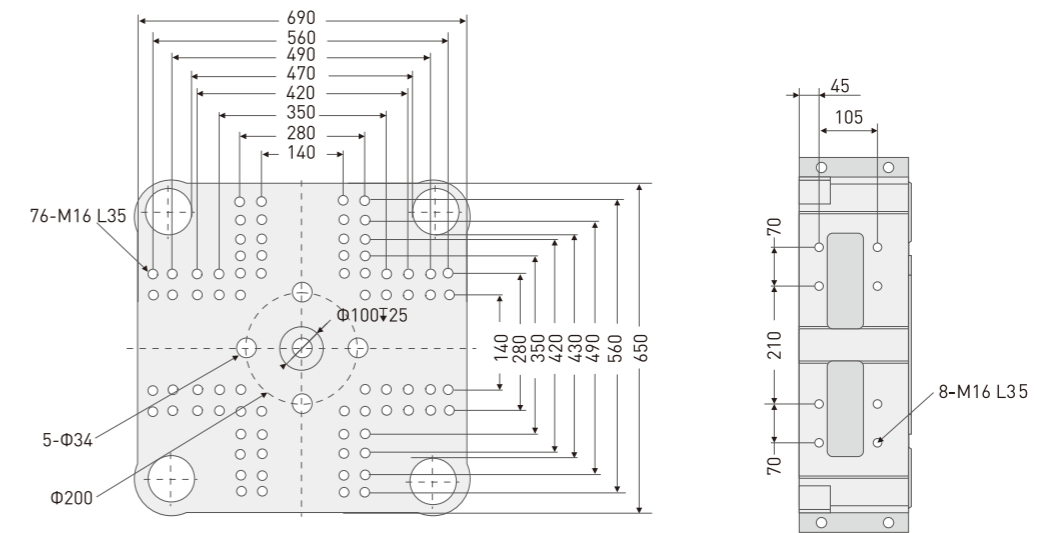

参数表 PARAMETERS

| 型号 | MODEL | SE-1500V | | | | | | | | | | |
|-------------|------------------------|----------|---------|--|--|--|--|--|--|--|--|--|
| 锁模力 | CLAMP TONNAGE | kN | 1500 | | | | | | | | | |
| 拉杆内间距 (HXV) | SPACE BETWEEN TIE-BARS | mm | 530x480 | | | | | | | | | |
| 模板尺寸 (HXV) | PLATEN DIMENSION | mm | 750x710 | | | | | | | | | |
| 移模行程 | OPEN STROKE | mm | 420 | | | | | | | | | |
| 模厚 | MOULD THICKNESS | mm | 200-550 | | | | | | | | | |
| 顶出行程 | EJECTOR STROKE | mm | 100 | | | | | | | | | |
| 顶出力 | EJECTOR FORCE | kN | 65 | | | | | | | | | |
| 顶出杆数 | EJECTOR NUMBER | | 5 | | | | | | | | | |
| 机器重量 | MACHINE WEIGHT | T | 7 | | | | | | | | | |

| | | | | | | | | | | | |
|-----------|----------------------------|-----------------|------|-----|-----|-------|-------|-----|------|-----|-----|
| 螺杆直径 | SCREW DIAMETER | mm | 30 | 34 | 38 | 36 | 40 | 45 | 40 | 45 | 50 |
| 注射容量 | INJECTION CAPACITY | cm ³ | 92 | 118 | 147 | 173 | 214 | 270 | 232 | 294 | 363 |
| 注射质量 (PS) | INJECTION WEIGHT (PS) | g | 84 | 107 | 134 | 157.5 | 194.4 | 246 | 212 | 268 | 331 |
| 塑化能力 (PS) | PLASTICIZING CAPACITY (PS) | kg/h | 42 | 61 | 82 | 71 | 91 | 123 | 91 | 123 | 150 |
| 螺杆转速 | SCREW SPEED | rpm | 400 | | | 350 | | | 350 | | |
| 温控段数 | HEATER BAND | | 3+1 | | | 3+1 | | | 3+1 | | |
| 加热功率 | HEATER POWER | kW | 7.8 | | | 10.3 | | | 12.3 | | |
| 喷嘴接触力 | NOZZLE PRESSING FORCE | kN | 19.6 | | | 29.4 | | | 29.4 | | |

| 标准注射单元 (STANDARD) | | | 240 | | | 450 | | | 570 | | |
|-------------------|-----------------------------|---------------------|------|------|------|------|------|------|------|------|------|
| 注射速度 | INJECTION SPEED | mm / s | 200 | | | 200 | | | 200 | | |
| 注射速率 (PS) | INJECTION RATE (PS) | cm ³ / s | 141 | 182 | 227 | 204 | 251 | 318 | 252 | 318 | 393 |
| 注射压力 | INJECTION PRESSURE | Mpa | 252 | 196 | 157 | 258 | 210 | 165 | 265 | 210 | 170 |
| | | kgf/cm ² | 2569 | 2000 | 1601 | 2636 | 2135 | 1687 | 2700 | 2135 | 1730 |
| 最大保压力 | MAX.INJECTION HOLD PRESSURE | Mpa | 202 | 157 | 126 | 207 | 167 | 132 | 213 | 168 | 136 |
| | | kgf/cm ² | 2055 | 1600 | 1281 | 2109 | 1708 | 1345 | 2169 | 1714 | 1388 |
| 总功率 | TOTAL POWER | kW | 28.2 | | | 40.3 | | | 42.3 | | |

| 选配注射单元 (OPTION) | | | 240H | | | 450H | | | 570H | | |
|-----------------|-----------------------------|---------------------|------|------|------|------|------|------|------|------|------|
| 注射速度 | INJECTION SPEED | mm / s | 350 | | | 350 | | | 350 | | |
| 注射速率 (PS) | INJECTION RATE (PS) | cm ³ / s | 247 | 318 | 397 | 357 | 440 | 557 | 441 | 557 | 688 |
| 注射压力 | INJECTION PRESSURE | Mpa | 252 | 196 | 157 | 258 | 210 | 165 | 265 | 210 | 170 |
| | | kgf/cm ² | 2569 | 2000 | 1601 | 2636 | 2135 | 1687 | 2700 | 2135 | 1730 |
| 最大保压力 | MAX.INJECTION HOLD PRESSURE | Mpa | 202 | 157 | 126 | 207 | 167 | 132 | 213 | 168 | 136 |
| | | kgf/cm ² | 2055 | 1600 | 1281 | 2109 | 1708 | 1345 | 2169 | 1714 | 1388 |
| 总功率 | TOTAL POWER | kW | 37.8 | | | 64.3 | | | 66.3 | | |

本公司保留修改技术参数的权利，恕不另行通知。 We reserve the right to change specifications without prior notice.

机器外形尺寸图 OVERALL DIMENSIONS

单位: mm

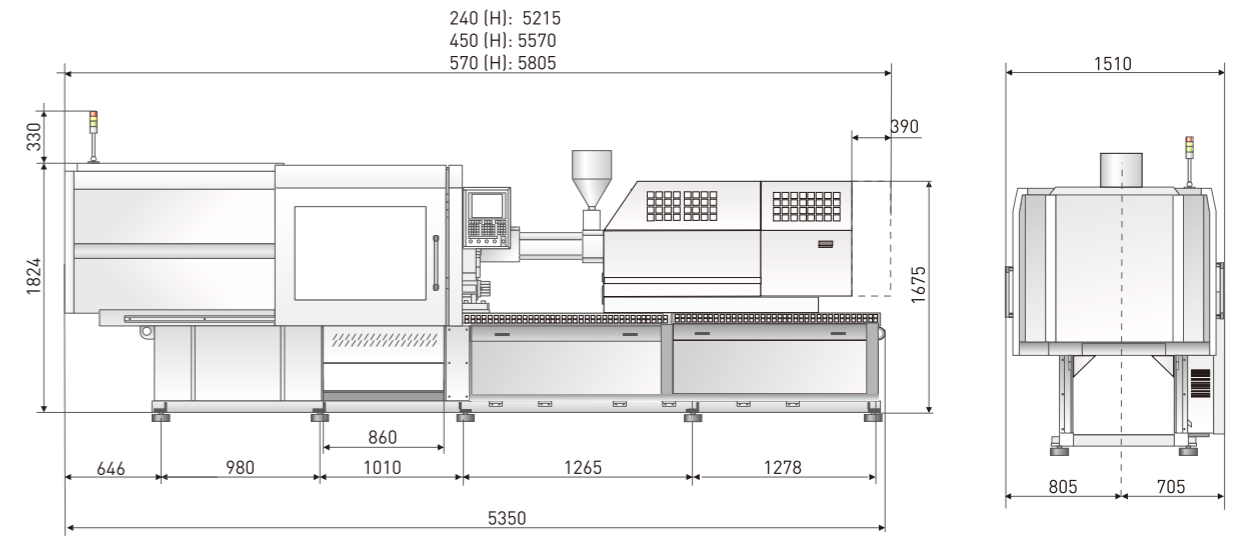

模板尺寸图 PLATEN DIMENSIONS

单位: mm

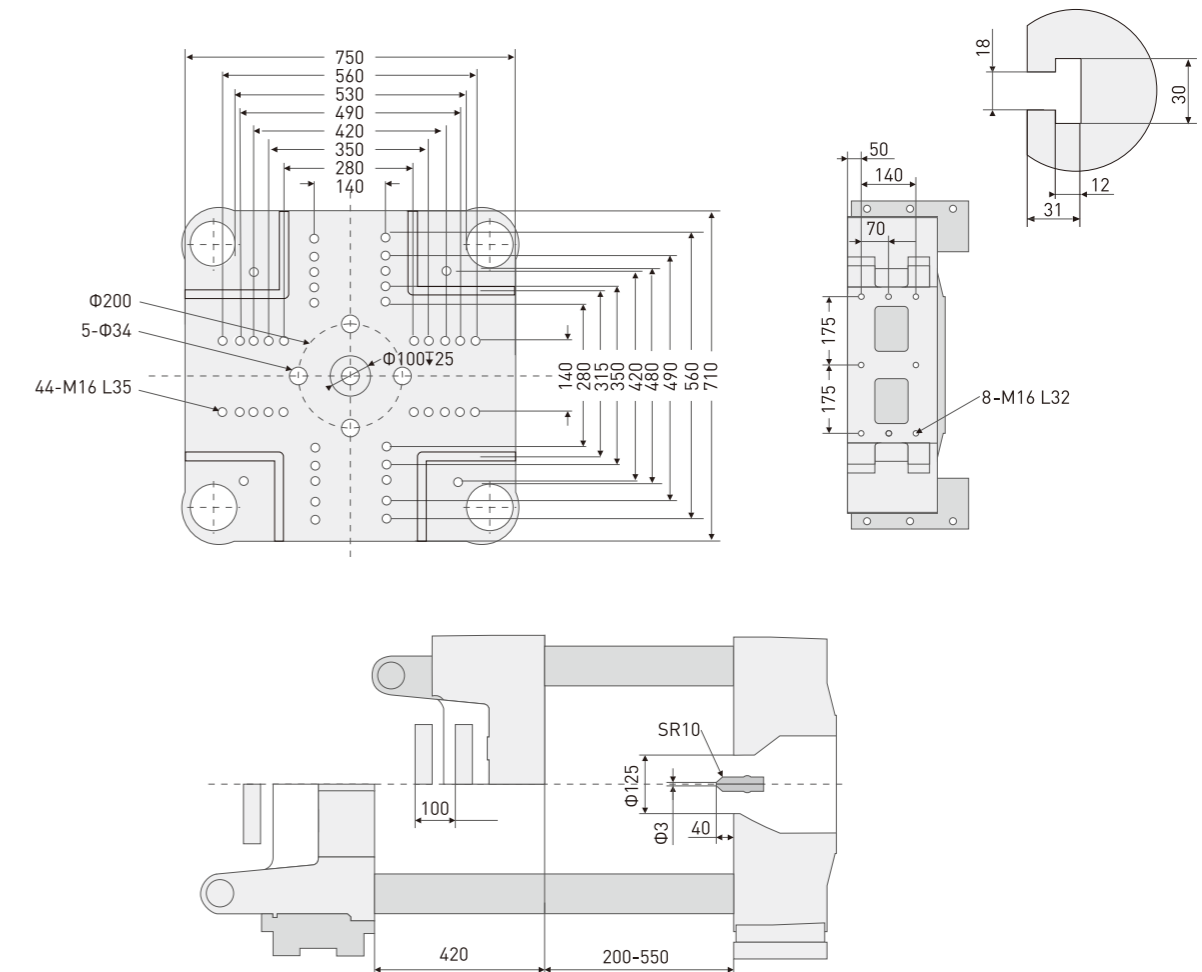

参数表 PARAMETERS

| 型号 | MODEL | SE-1900V | | | |
|-------------|------------------------|----------|---------|--|--|
| 锁模力 | CLAMP TONNAGE | kN | 1900 | | |
| 拉杆内间距 (HXV) | SPACE BETWEEN TIE-BARS | mm | 580x530 | | |
| 模板尺寸 (HXV) | PLATEN DIMENSION | mm | 820x800 | | |
| 移模行程 | OPEN STROKE | mm | 470 | | |
| 模厚 | MOULD THICKNESS | mm | 200-600 | | |
| 顶出行程 | EJECTOR STROKE | mm | 130 | | |
| 顶出力 | EJECTOR FORCE | kN | 65 | | |
| 顶出杆数 | EJECTOR NUMBER | | 9 | | |
| 机器重量 | MACHINE WEIGHT | T | 8.6 | | |

| 螺杆直径 | SCREW DIAMETER | mm | 36 | 40 | 45 | 40 | 45 | 50 | 45 | 50 | 55 |
|-----------|----------------------------|-----------------|-------|-------|-----|------|-----|-----|------|-----|-----|
| 注射容量 | INJECTION CAPACITY | cm ³ | 173 | 214 | 270 | 232 | 294 | 363 | 366 | 452 | 546 |
| 注射质量 (PS) | INJECTION WEIGHT (PS) | g | 157.5 | 194.4 | 246 | 212 | 268 | 331 | 333 | 411 | 497 |
| 塑化能力 (PS) | PLASTICIZING CAPACITY (PS) | kg/h | 71 | 91 | 123 | 91 | 123 | 150 | 123 | 150 | 175 |
| 螺杆转速 | SCREW SPEED | rpm | 350 | | | 350 | | | 350 | | |
| 温控段数 | HEATER BAND | | 3+1 | | | 3+1 | | | 4+1 | | |
| 加热功率 | HEATER POWER | kW | 10.3 | | | 12.3 | | | 14.4 | | |
| 喷嘴接触力 | NOZZLE PRESSING FORCE | kN | 29.4 | | | 29.4 | | | 29.4 | | |

| 标准注射单元 (STANDARD) | | 450 | | | 570 | | | 790 | | | |
|-------------------|-----------------------------|---------------------|------|------|------|------|------|------|------|------|------|
| 注射速度 | INJECTION SPEED | mm / s | 200 | | | 200 | | | 200 | | |
| 注射速率 (PS) | INJECTION RATE (PS) | cm ³ / s | 204 | 251 | 318 | 252 | 318 | 393 | 318 | 393 | 475 |
| 注射压力 | INJECTION PRESSURE | Mpa | 258 | 210 | 165 | 265 | 210 | 170 | 247 | 200 | 165 |
| | | kgf/cm ² | 2636 | 2135 | 1687 | 2700 | 2135 | 1730 | 2519 | 2040 | 1686 |
| 最大保压力 | MAX.INJECTION HOLD PRESSURE | Mpa | 207 | 167 | 132 | 213 | 168 | 136 | 197 | 160 | 132 |
| | | kgf/cm ² | 2109 | 1708 | 1345 | 2169 | 1714 | 1388 | 2015 | 1632 | 1349 |
| 总功率 | TOTAL POWER | kW | 40.3 | | | 42.3 | | | 68.4 | | |

| 选配注射单元 (OPTION) | | 450H | | | 570H | | | 790H | | | |
|-----------------|-----------------------------|---------------------|------|------|------|------|------|------|------|------|------|
| 注射速度 | INJECTION SPEED | mm / s | 350 | | | 350 | | | 350 | | |
| 注射速率 (PS) | INJECTION RATE (PS) | cm ³ / s | 357 | 440 | 557 | 441 | 557 | 688 | 557 | 688 | 831 |
| 注射压力 | INJECTION PRESSURE | Mpa | 258 | 210 | 165 | 265 | 210 | 170 | 247 | 200 | 165 |
| | | kgf/cm ² | 2636 | 2135 | 1687 | 2700 | 2135 | 1730 | 2519 | 2040 | 1686 |
| 最大保压力 | MAX.INJECTION HOLD PRESSURE | Mpa | 207 | 167 | 132 | 213 | 168 | 136 | 197 | 160 | 132 |
| | | kgf/cm ² | 2109 | 1708 | 1345 | 2169 | 1714 | 1388 | 2015 | 1632 | 1349 |
| 总功率 | TOTAL POWER | kW | 64.3 | | | 66.3 | | | 86.3 | | |

本公司保留修改技术参数的权利，恕不另行通知。 We reserve the right to change specifications without prior notice.

机器外形尺寸图 OVERALL DIMENSIONS

单位: mm

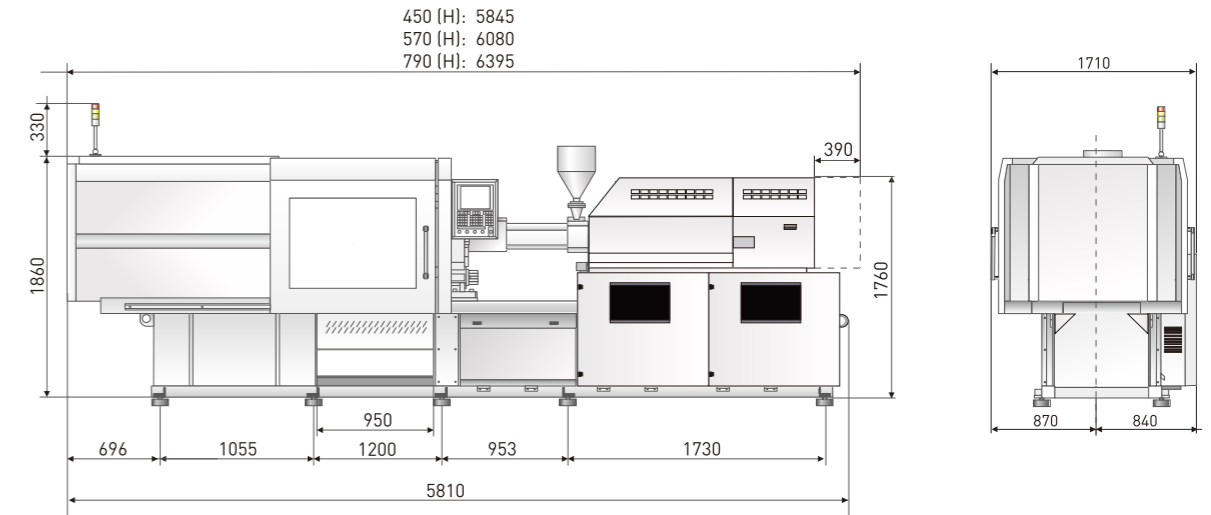

模板尺寸图 PLATEN DIMENSIONS

单位: mm

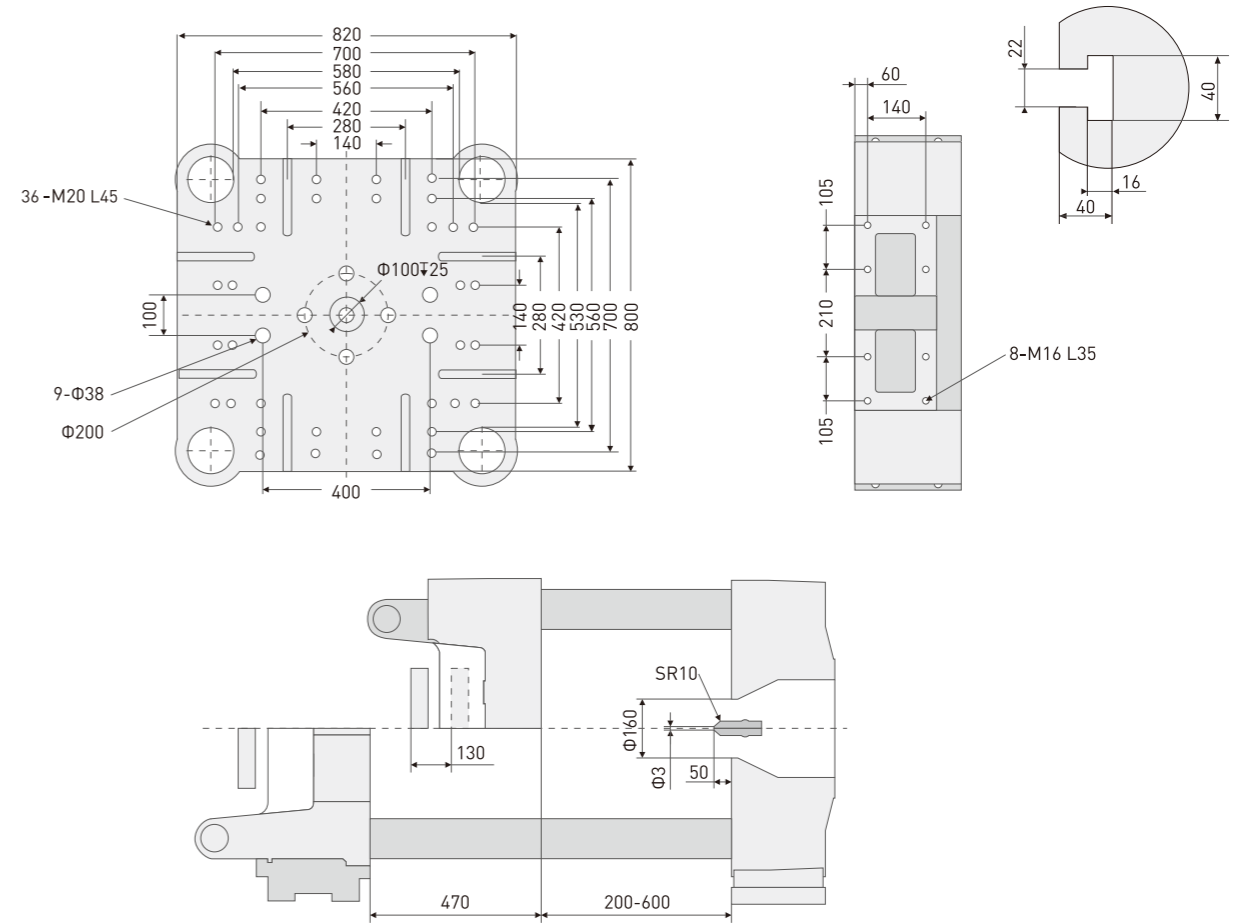

参数表 PARAMETERS

| 型号 | MODEL | SE-2300V | | | | | | | | | | |
|-------------|------------------------|----------|---------|--|--|--|--|--|--|--|--|--|
| 锁模力 | CLAMP TONNAGE | kN | 2300 | | | | | | | | | |
| 拉杆内间距 (HXV) | SPACE BETWEEN TIE-BARS | mm | 625x575 | | | | | | | | | |
| 模板尺寸 (HXV) | PLATEN DIMENSION | mm | 880x860 | | | | | | | | | |
| 移模行程 | OPEN STROKE | mm | 550 | | | | | | | | | |
| 模厚 | MOULD THICKNESS | mm | 250-680 | | | | | | | | | |
| 顶出行程 | EJECTOR STROKE | mm | 150 | | | | | | | | | |
| 顶出力 | EJECTOR FORCE | kN | 76 | | | | | | | | | |
| 顶出杆数 | EJECTOR NUMBER | | 13 | | | | | | | | | |
| 机器重量 | MACHINE WEIGHT | T | 11 | | | | | | | | | |

| | | | | | | | | | | | |
|-----------|----------------------------|-----------------|-----|------|-----|-----|------|-----|-----|------|-----|
| 螺杆直径 | SCREW DIAMETER | mm | 40 | 45 | 50 | 45 | 50 | 55 | 50 | 55 | 60 |
| 注射容量 | INJECTION CAPACITY | cm ³ | 232 | 294 | 363 | 366 | 452 | 546 | 511 | 618 | 735 |
| 注射质量 (PS) | INJECTION WEIGHT (PS) | g | 212 | 268 | 331 | 333 | 411 | 497 | 465 | 562 | 669 |
| 塑化能力 (PS) | PLASTICIZING CAPACITY (PS) | kg/h | 91 | 123 | 150 | 123 | 150 | 175 | 136 | 212 | 242 |
| 螺杆转速 | SCREW SPEED | rpm | | 350 | | | 350 | | | 320 | |
| 温控段数 | HEATER BAND | | | 3+1 | | | 4+1 | | | 4+1 | |
| 加热功率 | HEATER POWER | kW | | 12.3 | | | 14.4 | | | 17.5 | |
| 喷嘴接触力 | NOZZLE PRESSING FORCE | kN | | 29.4 | | | 29.4 | | | 39.2 | |

| 标准注射单元 (STANDARD) | | | 570 | 790 | 1020 | | | | | | |
|-------------------|-----------------------------|---------------------|------|------|------|------|------|------|------|------|------|
| 注射速度 | INJECTION SPEED | mm / s | 200 | 200 | 160 | | | | | | |
| 注射速率 (PS) | INJECTION RATE (PS) | cm ³ / s | 252 | 318 | 393 | 318 | 393 | 475 | 314 | 380 | 452 |
| 注射压力 | INJECTION PRESSURE | Mpa | 265 | 210 | 170 | 247 | 200 | 165 | 218 | 180 | 152 |
| | | kgf/cm ² | 2700 | 2135 | 1730 | 2519 | 2040 | 1686 | 2135 | 1836 | 1560 |
| 最大保压力 | MAX.INJECTION HOLD PRESSURE | Mpa | 213 | 168 | 136 | 197 | 160 | 132 | 175 | 144 | 121 |
| | | kgf/cm ² | 2169 | 1714 | 1388 | 2015 | 1632 | 1349 | 1707 | 1470 | 1186 |
| 总功率 | TOTAL POWER | kW | 42.3 | | 68.4 | | 59.6 | | | | |

| 选配注射单元 (OPTION) | | | 570H | 790H | 1020H | | | | | | |
|-----------------|-----------------------------|---------------------|------|------|-------|------|------|------|------|------|------|
| 注射速度 | INJECTION SPEED | mm / s | 350 | 350 | 250 | | | | | | |
| 注射速率 (PS) | INJECTION RATE (PS) | cm ³ / s | 441 | 557 | 688 | 557 | 688 | 831 | 500 | 602 | 718 |
| 注射压力 | INJECTION PRESSURE | Mpa | 265 | 210 | 170 | 247 | 200 | 165 | 218 | 180 | 152 |
| | | kgf/cm ² | 2700 | 2135 | 1730 | 2519 | 2040 | 1686 | 2135 | 1836 | 1560 |
| 最大保压力 | MAX.INJECTION HOLD PRESSURE | Mpa | 213 | 168 | 136 | 197 | 160 | 132 | 175 | 144 | 121 |
| | | kgf/cm ² | 2169 | 1714 | 1388 | 2015 | 1632 | 1349 | 1707 | 1470 | 1186 |
| 总功率 | TOTAL POWER | kW | 66.3 | | 86.3 | | 89.5 | | | | |

本公司保留修改技术参数的权利，恕不另行通知。 We reserve the right to change specifications without prior notice.

机器外形尺寸图 OVERALL DIMENSIONS

单位: mm

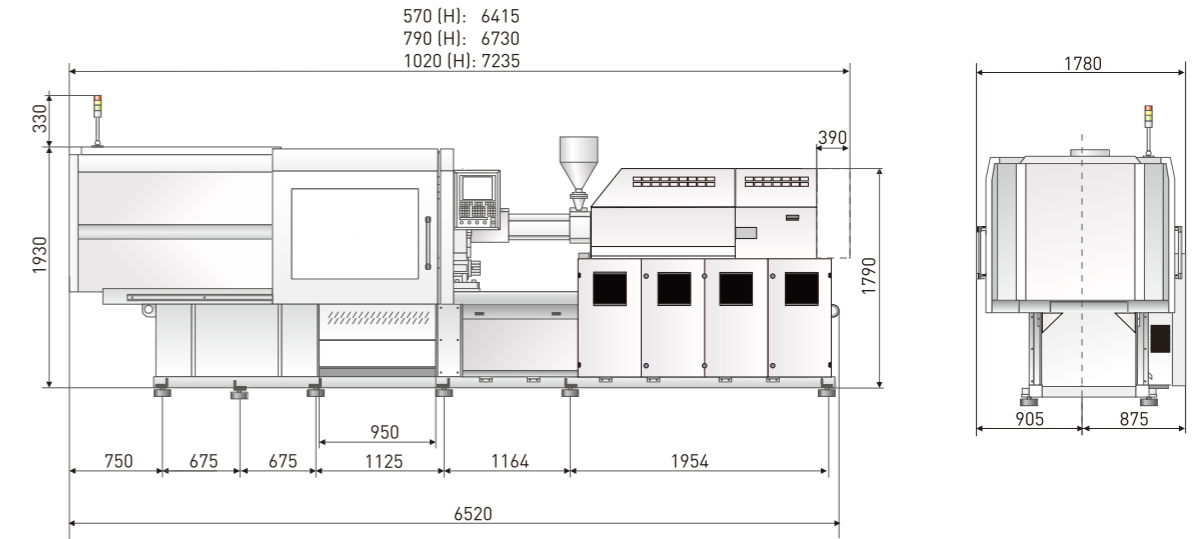

模板尺寸图 PLATEN DIMENSIONS

单位: mm

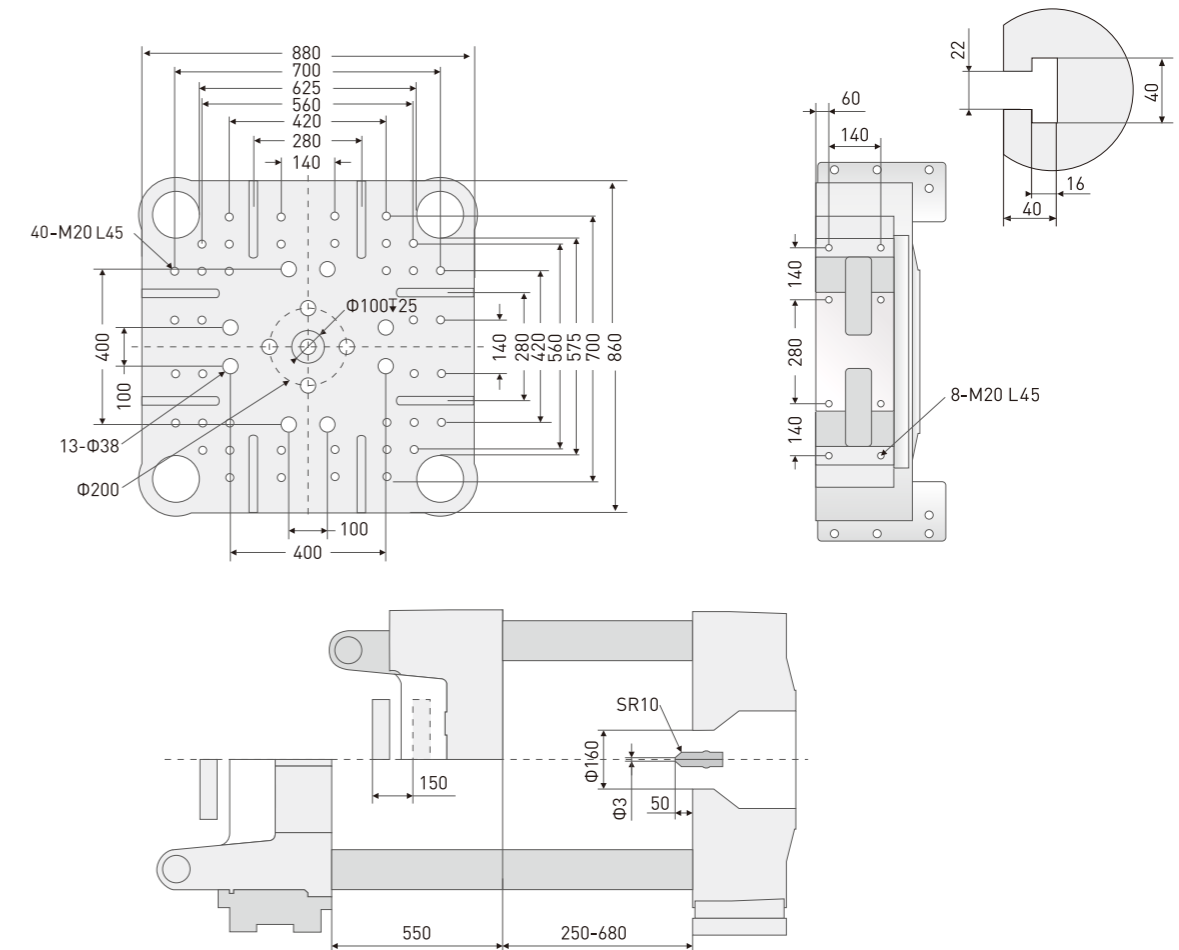

参数表 PARAMETERS

| 型号 | MODEL | SE-3000V | | | | | | | | | | |
|-------------|------------------------|----------|----------|--|--|--|--|--|--|--|--|--|
| 锁模力 | CLAMP TONNAGE | kN | 3000 | | | | | | | | | |
| 拉杆内间距 (HXV) | SPACE BETWEEN TIE-BARS | mm | 730x680 | | | | | | | | | |
| 模板尺寸 (HXV) | PLATEN DIMENSION | mm | 1020x960 | | | | | | | | | |
| 移模行程 | OPEN STROKE | mm | 600 | | | | | | | | | |
| 模厚 | MOULD THICKNESS | mm | 250-750 | | | | | | | | | |
| 顶出行程 | EJECTOR STROKE | mm | 180 | | | | | | | | | |
| 顶出力 | EJECTOR FORCE | kN | 76 | | | | | | | | | |
| 顶出杆数 | EJECTOR NUMBER | | 13 | | | | | | | | | |
| 机器重量 | MACHINE WEIGHT | T | 14.9 | | | | | | | | | |

| 螺杆直径 | SCREW DIAMETER | mm | 45 | 50 | 55 | 50 | 55 | 60 | 55 | 60 | 65 |
|-----------|----------------------------|-----------------|------|-----|-----|------|-----|-----|------|-----|-----|
| 注射容量 | INJECTION CAPACITY | cm ³ | 366 | 452 | 546 | 511 | 618 | 735 | 665 | 792 | 929 |
| 注射质量 (PS) | INJECTION WEIGHT (PS) | g | 333 | 411 | 497 | 465 | 562 | 669 | 605 | 720 | 846 |
| 塑化能力 (PS) | PLASTICIZING CAPACITY (PS) | kg/h | 123 | 150 | 175 | 136 | 212 | 242 | 206 | 226 | 252 |
| 螺杆转速 | SCREW SPEED | rpm | | 350 | | | 320 | | | 320 | |
| 温控段数 | HEATER BAND | | 4+1 | | | 4+1 | | | 4+1 | | |
| 加热功率 | HEATER POWER | kW | 14.4 | | | 17.5 | | | 20.2 | | |
| 喷嘴接触力 | NOZZLE PRESSING FORCE | kN | 29.4 | | | 39.2 | | | 39.2 | | |

| 标准注射单元 (STANDARD) | | | 790 | | | 1020 | | | 1370 | | |
|-------------------|-----------------------------|---------------------|------|------|------|------|------|------|------|------|------|
| 注射速度 | INJECTION SPEED | mm/s | 200 | | | 160 | | | 160 | | |
| 注射速率 (PS) | INJECTION RATE (PS) | cm ³ /s | 318 | 393 | 475 | 314 | 380 | 452 | 380 | 452 | 530 |
| 注射压力 | INJECTION PRESSURE | Mpa | 247 | 200 | 165 | 218 | 180 | 152 | 214 | 180 | 153 |
| | | kgf/cm ² | 2519 | 2040 | 1686 | 2135 | 1836 | 1560 | 2183 | 1836 | 1561 |
| 最大保压力 | MAX.INJECTION HOLD PRESSURE | Mpa | 197 | 160 | 132 | 175 | 144 | 121 | 171 | 144 | 122 |
| | | kgf/cm ² | 2015 | 1632 | 1349 | 1707 | 1470 | 1186 | 1746 | 1469 | 1249 |
| 总功率 | TOTAL POWER | kW | 68.4 | | | 59.6 | | | 70.2 | | |

| 选配注射单元 (OPTION) | | | 790H | | | 1020H | | | 1370H | | |
|-----------------|-----------------------------|---------------------|------|------|------|-------|------|------|-------|------|------|
| 注射速度 | INJECTION SPEED | mm/s | 350 | | | 250 | | | 250 | | |
| 注射速率 (PS) | INJECTION RATE (PS) | cm ³ /s | 557 | 688 | 831 | 500 | 602 | 718 | 593 | 706 | 828 |
| 注射压力 | INJECTION PRESSURE | Mpa | 247 | 200 | 165 | 218 | 180 | 152 | 214 | 180 | 153 |
| | | kgf/cm ² | 2519 | 2040 | 1686 | 2135 | 1836 | 1560 | 2183 | 1836 | 1561 |
| 最大保压力 | MAX.INJECTION HOLD PRESSURE | Mpa | 197 | 160 | 132 | 175 | 144 | 121 | 171 | 144 | 122 |
| | | kgf/cm ² | 2015 | 1632 | 1349 | 1707 | 1470 | 1186 | 1746 | 1469 | 1249 |
| 总功率 | TOTAL POWER | kW | 86.3 | | | 89.5 | | | 100.2 | | |

本公司保留修改技术参数的权利, 恕不另行通知。 We reserve the right to change specifications without prior notice.

机器外形尺寸图 OVERALL DIMENSIONS

单位: mm

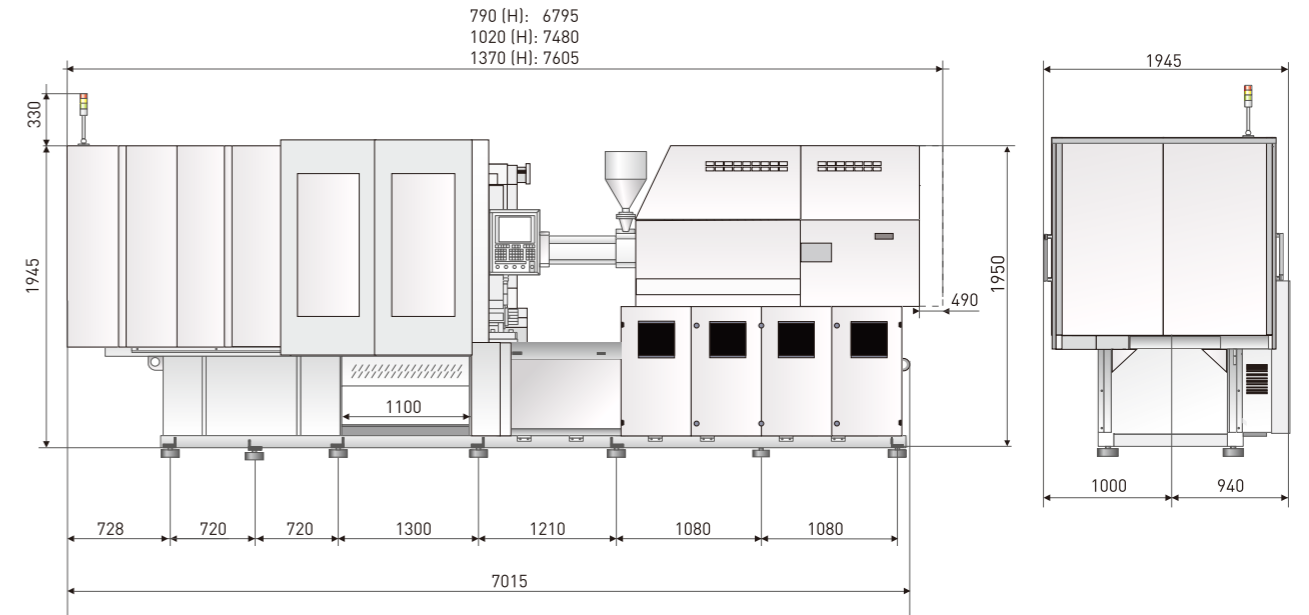

模板尺寸图 PLATEN DIMENSIONS

单位: mm

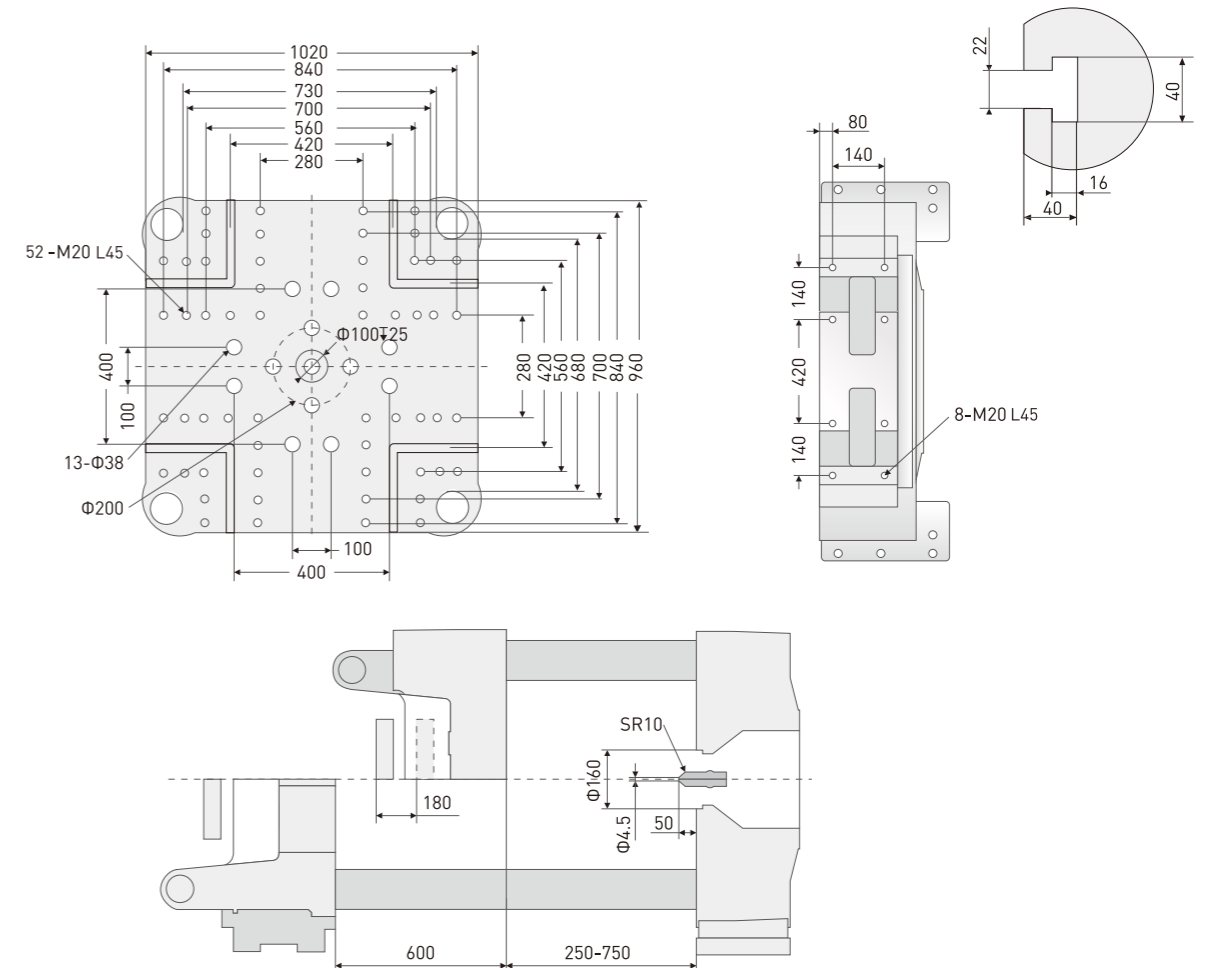

参数表 PARAMETERS

| 型号 | MODEL | SE-3600V | |
|-------------|------------------------|----------|-----------|
| 锁模力 | CLAMP TONNAGE | kN | 3600 |
| 拉杆内间距 (HXV) | SPACE BETWEEN TIE-BARS | mm | 830x780 |
| 模板尺寸 (HXV) | PLATEN DIMENSION | mm | 1150x1120 |
| 移模行程 | OPEN STROKE | mm | 700 |
| 模厚 | MOULD THICKNESS | mm | 250-800 |
| 顶出行程 | EJECTOR STROKE | mm | 180 |
| 顶出力 | EJECTOR FORCE | kN | 120 |
| 顶出杆数 | EJECTOR NUMBER | | 13 |
| 机器重量 | MACHINE WEIGHT | T | 19.8 |

| 螺杆直径 | SCREW DIAMETER | mm | 50 | 55 | 60 | 55 | 60 | 65 | 60 | 65 | 70 |
|-----------|----------------------------|-----------------|-----|------|-----|------|-----|-----|-----|------|------|
| 注射容量 | INJECTION CAPACITY | cm ³ | 511 | 618 | 735 | 665 | 792 | 929 | 891 | 1045 | 1212 |
| 注射质量 (PS) | INJECTION WEIGHT (PS) | g | 465 | 562 | 669 | 605 | 720 | 846 | 810 | 951 | 1103 |
| 塑化能力 (PS) | PLASTICIZING CAPACITY (PS) | kg/h | 136 | 212 | 242 | 206 | 226 | 252 | 226 | 252 | 290 |
| 螺杆转速 | SCREW SPEED | rpm | | 320 | | 320 | | | | 250 | |
| 温控段数 | HEATER BAND | | | 4+1 | | 4+1 | | | | 4+1 | |
| 加热功率 | HEATER POWER | kW | | 17.5 | | 20.2 | | | | 23.6 | |
| 喷嘴接触力 | NOZZLE PRESSING FORCE | kN | | 39.2 | | 39.2 | | | | 58.8 | |

| 标准注射单元 (STANDARD) | | | 1020 | 1370 | 1790 |
|-------------------|-----------------------------|---------------------|------|------|------|
| 注射速度 | INJECTION SPEED | mm / s | 160 | 160 | 160 |
| 注射速率 (PS) | INJECTION RATE (PS) | cm ³ / s | 314 | 380 | 452 |
| 注射压力 | INJECTION PRESSURE | Mpa | 218 | 180 | 152 |
| | | kgf/cm ² | 2135 | 1836 | 1560 |
| 最大保压力 | MAX.INJECTION HOLD PRESSURE | Mpa | 175 | 144 | 121 |
| | | kgf/cm ² | 1707 | 1470 | 1186 |
| 总功率 | TOTAL POWER | kW | 59.6 | 70.2 | 73.6 |

| 选配注射单元 (OPTION) | | | 1020H | 1370H | 1790H |
|-----------------|-----------------------------|---------------------|-------|-------|-------|
| 注射速度 | INJECTION SPEED | mm / s | 250 | 250 | 250 |
| 注射速率 (PS) | INJECTION RATE (PS) | cm ³ / s | 500 | 602 | 718 |
| 注射压力 | INJECTION PRESSURE | Mpa | 218 | 180 | 152 |
| | | kgf/cm ² | 2135 | 1836 | 1560 |
| 最大保压力 | MAX.INJECTION HOLD PRESSURE | Mpa | 175 | 144 | 121 |
| | | kgf/cm ² | 1707 | 1470 | 1186 |
| 总功率 | TOTAL POWER | kW | 89.5 | 100.2 | 103.6 |

机器外形尺寸图 OVERALL DIMENSIONS

单位: mm

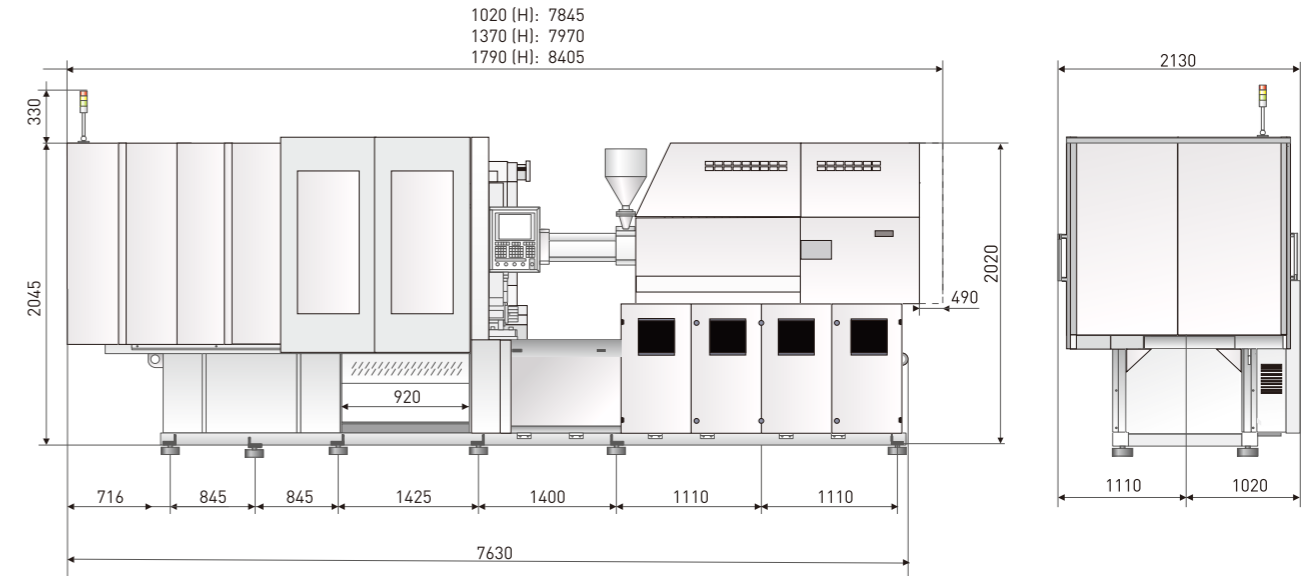

模板尺寸图 PLATEN DIMENSIONS

单位: mm

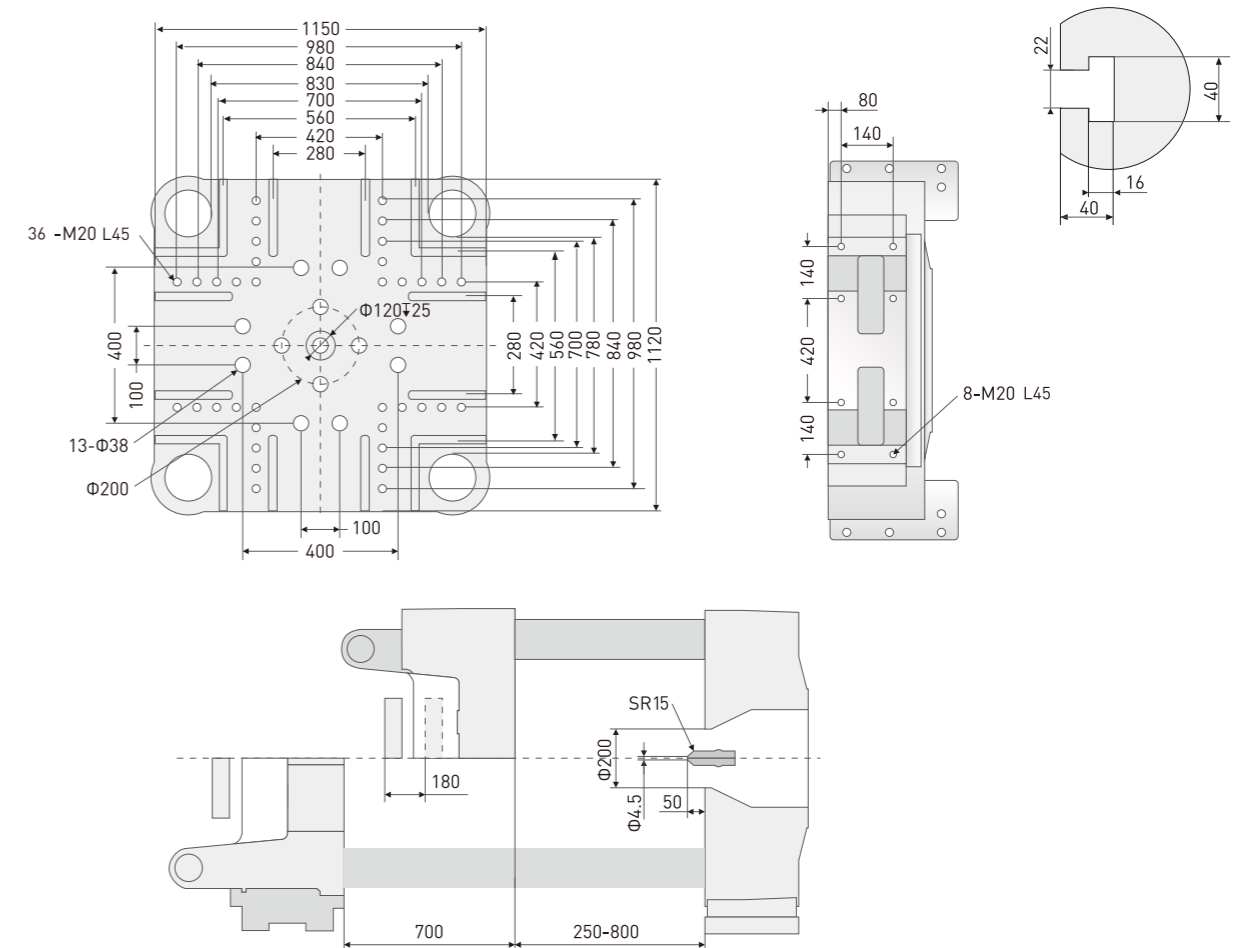

参数表 PARAMETERS

| 型号 | MODEL | SE-4500V | |
|-------------|------------------------|----------|-----------|
| 锁模力 | CLAMP TONNAGE | kN | 4500 |
| 拉杆内间距 (HXV) | SPACE BETWEEN TIE-BARS | mm | 880x855 |
| 模板尺寸 (HXV) | PLATEN DIMENSION | mm | 1300x1260 |
| 移模行程 | OPEN STROKE | mm | 820 |
| 模厚 | MOULD THICKNESS | mm | 350-870 |
| 顶出行程 | EJECTOR STROKE | mm | 180 |
| 顶出力 | EJECTOR FORCE | kN | 120 |
| 顶出杆数 | EJECTOR NUMBER | | 21 |
| 机器重量 | MACHINE WEIGHT | T | 28.8 |

| 螺杆直径 | SCREW DIAMETER | mm | 55 | 60 | 65 | 60 | 65 | 70 | 65 | 70 | 80 |
|-----------|----------------------------|-----------------|------|-----|-----|------|------|------|------|------|------|
| 注射容量 | INJECTION CAPACITY | cm ³ | 665 | 792 | 929 | 891 | 1045 | 1212 | 1128 | 1308 | 1709 |
| 注射质量 (PS) | INJECTION WEIGHT (PS) | g | 605 | 720 | 846 | 810 | 951 | 1103 | 1027 | 1191 | 1555 |
| 塑化能力 (PS) | PLASTICIZING CAPACITY (PS) | kg/h | 206 | 226 | 252 | 226 | 252 | 290 | 252 | 290 | 320 |
| 螺杆转速 | SCREW SPEED | rpm | 320 | | | 250 | | | 210 | | |
| 温控段数 | HEATER BAND | | 4+1 | | | 4+1 | | | 4+1 | | |
| 加热功率 | HEATER POWER | kW | 20.2 | | | 23.6 | | | 29.1 | | |
| 喷嘴接触力 | NOZZLE PRESSING FORCE | kN | 39.2 | | | 58.8 | | | 65 | | |

| 标准注射单元 (STANDARD) | | | 1370 | 1790 | 2280 | | | | | | |
|-------------------|-----------------------------|---------------------|------|------|------|------|------|------|------|------|------|
| 注射速度 | INJECTION SPEED | mm / s | 160 | | | | | | | | |
| 注射速率 (PS) | INJECTION RATE (PS) | cm ³ / s | 380 | 452 | 530 | 452 | 531 | 616 | 531 | 616 | 804 |
| 注射压力 | INJECTION PRESSURE | MPa | 214 | 180 | 153 | 211 | 180 | 155 | 215 | 185 | 140 |
| | | kgf/cm ² | 2183 | 1836 | 1561 | 2155 | 1836 | 1583 | 2193 | 1887 | 1428 |
| 最大保压力 | MAX.INJECTION HOLD PRESSURE | MPa | 171 | 144 | 122 | 169 | 144 | 124 | 172 | 148 | 112 |
| | | kgf/cm ² | 1746 | 1469 | 1249 | 1724 | 1469 | 1266 | 1755 | 1510 | 1142 |
| 总功率 | TOTAL POWER | | 70.2 | | | 73.6 | | | 137 | | |

| 选配注射单元 (OPTION) | | | 1370H | 1790H | - | | | | | | |
|-----------------|-----------------------------|---------------------|-------|-------|------|------|------|------|---|---|---|
| 注射速度 | INJECTION SPEED | mm / s | 250 | | | | | | | | |
| 注射速率 (PS) | INJECTION RATE (PS) | cm ³ / s | 593 | 706 | 828 | 706 | 830 | 963 | - | - | - |
| 注射压力 | INJECTION PRESSURE | MPa | 214 | 180 | 153 | 211 | 180 | 155 | - | - | - |
| | | kgf/cm ² | 2183 | 1836 | 1561 | 2155 | 1836 | 1583 | - | - | - |
| 最大保压力 | MAX.INJECTION HOLD PRESSURE | MPa | 171 | 144 | 122 | 169 | 144 | 124 | - | - | - |
| | | kgf/cm ² | 1746 | 1469 | 1249 | 1724 | 1469 | 1266 | - | - | - |
| 总功率 | TOTAL POWER | kW | 100.2 | | | 104 | | | | | |

本公司保留修改技术参数的权利，恕不另行通知。 We reserve the right to change specifications without prior notice.

机器外形尺寸图 OVERALL DIMENSIONS

单位: mm

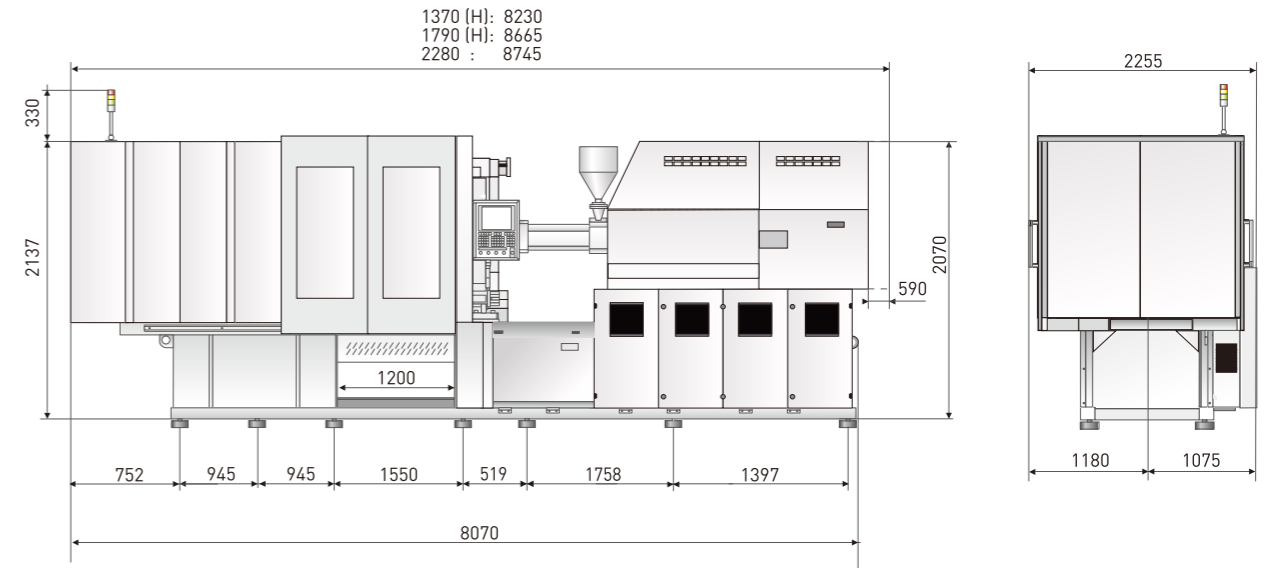

模板尺寸图 PLATEN DIMENSIONS

单位: mm

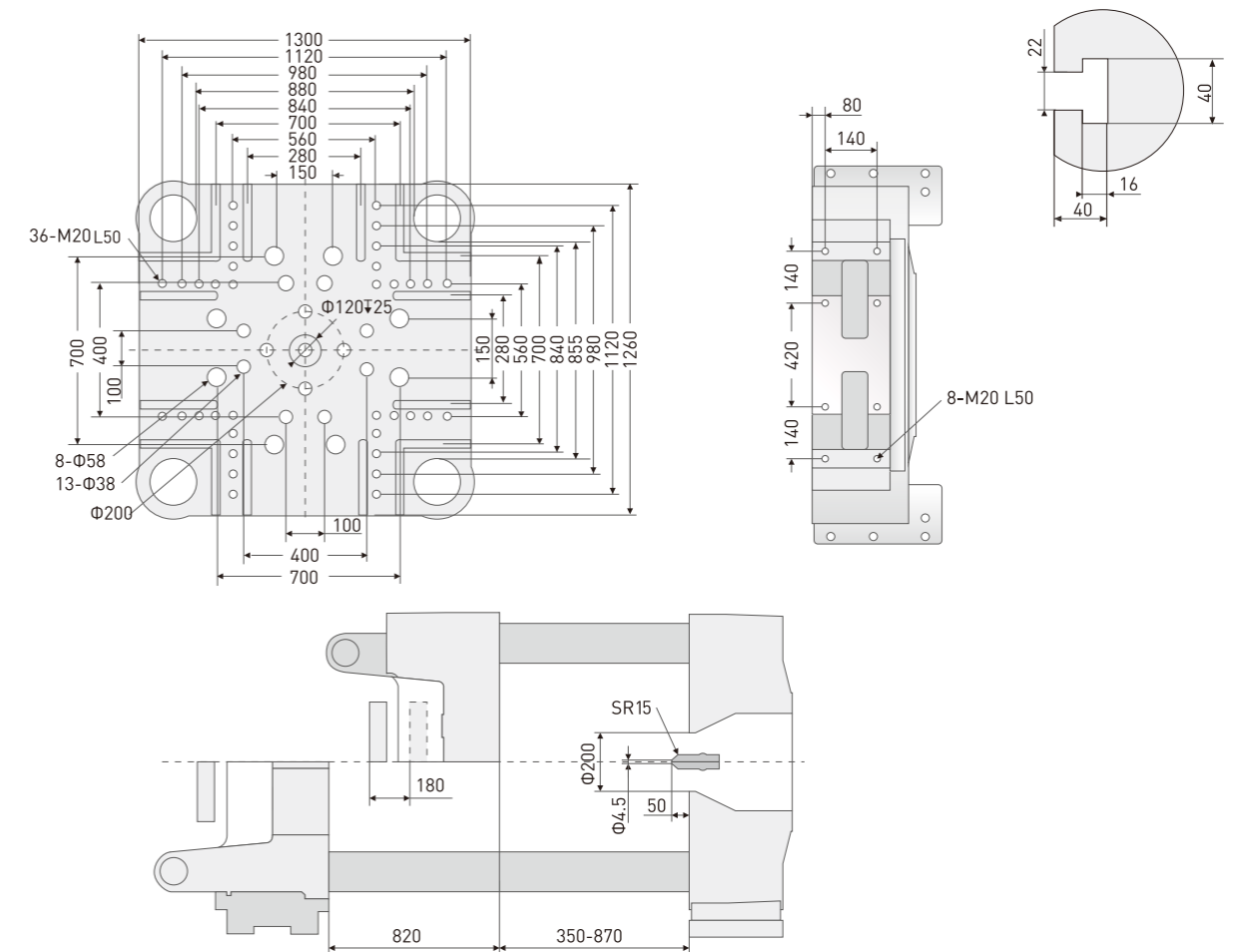

参数表 PARAMETERS

| 型号 | MODEL | SE-5500V | |
|-------------|------------------------|----------|-----------|
| 锁模力 | CLAMP TONNAGE | kN | 5500 |
| 拉杆内间距 (HXV) | SPACE BETWEEN TIE-BARS | mm | 915x855 |
| 模板尺寸 (HXV) | PLATEN DIMENSION | mm | 1330x1260 |
| 移模行程 | OPEN STROKE | mm | 850 |
| 模厚 | MOULD THICKNESS | mm | 350-900 |
| 顶出行程 | EJECTOR STROKE | mm | 180 |
| 顶出力 | EJECTOR FORCE | kN | 120 |
| 顶出杆数 | EJECTOR NUMBER | | 21 |
| 机器重量 | MACHINE WEIGHT | T | 32.5 |

| 螺杆直径 | SCREW DIAMETER | mm | 60 | 65 | 70 | 65 | 70 | 80 | 75 | 80 | 90 |
|-----------|----------------------------|-----------------|-----|------|------|------|------|------|------|------|------|
| 注射容量 | INJECTION CAPACITY | cm ³ | 891 | 1045 | 1212 | 1128 | 1308 | 1709 | 1679 | 1910 | 2417 |
| 注射质量 (PS) | INJECTION WEIGHT (PS) | g | 810 | 951 | 1103 | 1027 | 1191 | 1555 | 1528 | 1738 | 2200 |
| 塑化能力 (PS) | PLASTICIZING CAPACITY (PS) | kg/h | 226 | 252 | 290 | 252 | 290 | 320 | 304 | 320 | 361 |
| 螺杆转速 | SCREW SPEED | rpm | | 250 | | | 210 | | | 190 | |
| 温控段数 | HEATER BAND | | | 4+1 | | | 4+1 | | | 5+1 | |
| 加热功率 | HEATER POWER | kW | | 23.6 | | | 39.1 | | | 44.1 | |
| 喷嘴接触力 | NOZZLE PRESSING FORCE | kN | | 58.8 | | | 65 | | | 75 | |

| 标准注射单元 (STANDARD) | | | 1790 | | | 2280 | | | 3340 | | |
|-------------------|-----------------------------|---------------------|------|------|------|------|------|------|------|------|------|
| 注射速度 | INJECTION SPEED | mm / s | 160 | | | 160 | | | 160 | | |
| 注射速率 (PS) | INJECTION RATE (PS) | cm ³ / s | 452 | 531 | 616 | 531 | 616 | 804 | 707 | 804 | 1018 |
| 注射压力 | INJECTION PRESSURE | MPa | 211 | 180 | 155 | 215 | 185 | 140 | 215 | 190 | 150 |
| | | kgf/cm ² | 2155 | 1836 | 1583 | 2193 | 1887 | 1428 | 2193 | 1938 | 1530 |
| 最大保压力 | MAX.INJECTION HOLD PRESSURE | MPa | 169 | 144 | 124 | 172 | 148 | 112 | 172 | 152 | 120 |
| | | kgf/cm ² | 1724 | 1469 | 1266 | 1755 | 1510 | 1142 | 1755 | 1550 | 1224 |
| 总功率 | TOTAL POWER | kW | 73.6 | | | 137 | | | 165 | | |

机器外形尺寸图 OVERALL DIMENSIONS

单位: mm

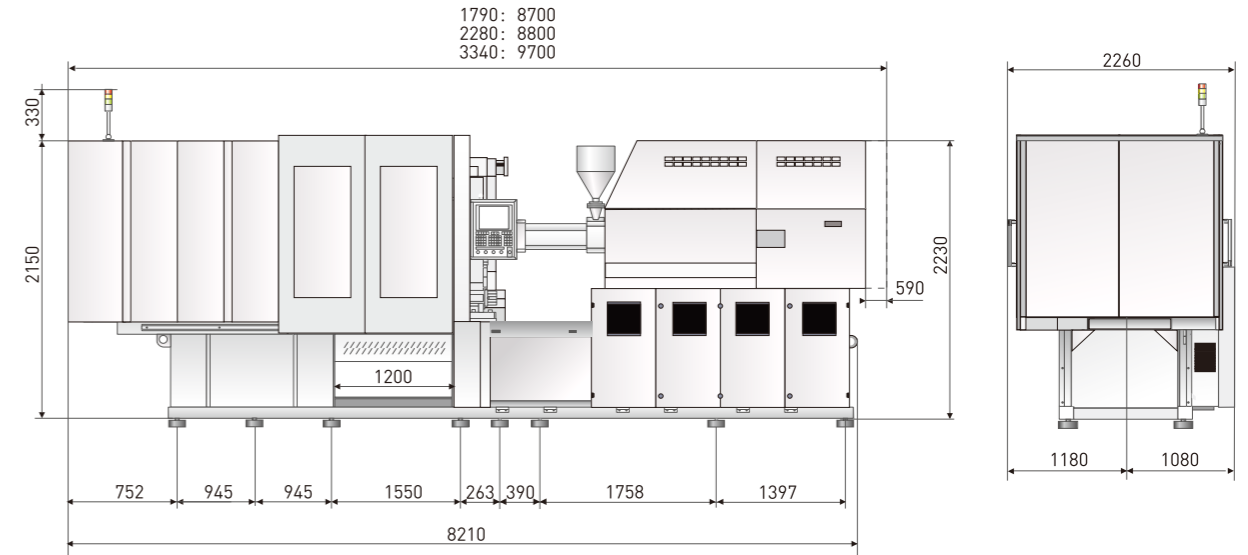

模板尺寸图 PLATEN DIMENSIONS

单位: mm

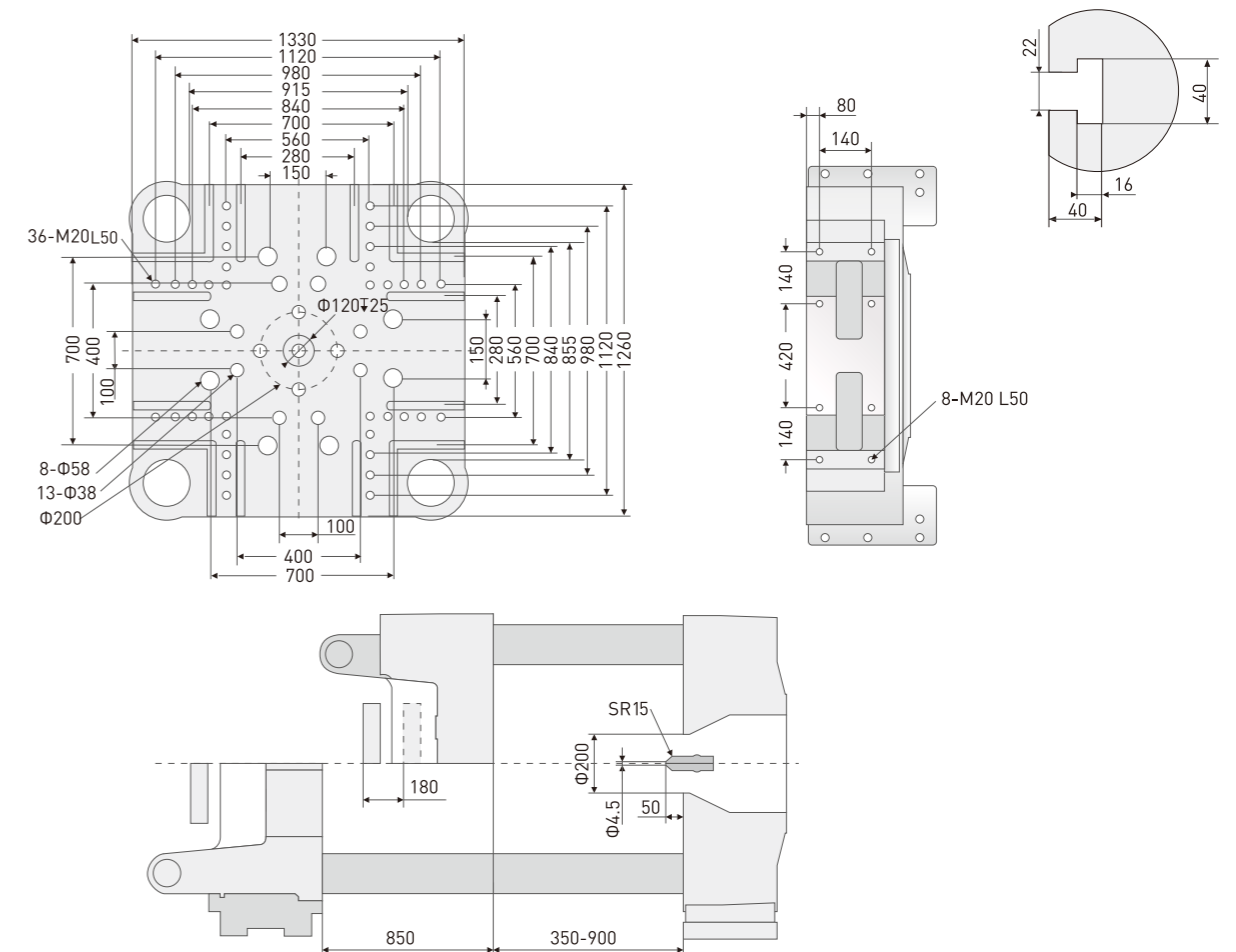

参数表 PARAMETERS

| 型号 | MODEL | SE-6500V | |
|-------------|------------------------|----------|-----------|
| 锁模力 | CLAMP TONNAGE | kN | 6500 |
| 拉杆内间距 (HXV) | SPACE BETWEEN TIE-BARS | mm | 1080x1080 |
| 模板尺寸 (HXV) | PLATEN DIMENSION | mm | 1550x1550 |
| 移模行程 | OPEN STROKE | mm | 1000 |
| 模厚 | MOULD THICKNESS | mm | 420-1000 |
| 顶出行程 | EJECTOR STROKE | mm | 200 |
| 顶出力 | EJECTOR FORCE | kN | 250 |
| 顶出杆数 | EJECTOR NUMBER | | 21 |
| 机器重量 | MACHINE WEIGHT | T | 41 |

| 螺杆直径 | SCREW DIAMETER | mm | 65 | 70 | 80 | 75 | 80 | 90 | 80 | 90 | 100 |
|-----------|----------------------------|-----------------|------|------|------|------|------|------|------|------|------|
| 注射容量 | INJECTION CAPACITY | cm ³ | 1128 | 1308 | 1709 | 1679 | 1910 | 2417 | 2312 | 2926 | 3613 |
| 注射质量 (PS) | INJECTION WEIGHT (PS) | g | 1027 | 1191 | 1555 | 1528 | 1738 | 2200 | 2104 | 2663 | 3288 |
| 塑化能力 (PS) | PLASTICIZING CAPACITY (PS) | kg/h | 252 | 290 | 320 | 304 | 320 | 361 | 320 | 361 | 412 |
| 螺杆转速 | SCREW SPEED | rpm | 210 | | | 190 | | | 165 | | |
| 温控段数 | HEATER BAND | | 5+1 | | | 6+1 | | | 7+1 | | |
| 加热功率 | HEATER POWER | kW | 29.1 | | | 38 | | | 51 | | |
| 喷嘴接触力 | NOZZLE PRESSING FORCE | kN | 65 | | | 75 | | | 75 | | |

| 标准注射单元 (STANDARD) | | | 2280 | 3340 | 5150 | | | | | | |
|-------------------|-----------------------------|---------------------|------|------|------|------|------|------|------|------|------|
| 注射速度 | INJECTION SPEED | mm / s | 160 | | | | | | | | |
| 注射速率 (PS) | INJECTION RATE (PS) | cm ³ / s | 531 | 616 | 804 | 707 | 804 | 1018 | 754 | 954 | 1178 |
| 注射压力 | INJECTION PRESSURE | MPa | 215 | 185 | 140 | 215 | 190 | 150 | 190 | 180 | 155 |
| | | kgf/cm ² | 2193 | 1887 | 1428 | 2193 | 1938 | 1530 | 1938 | 1836 | 1530 |
| 最大保压力 | MAX.INJECTION HOLD PRESSURE | MPa | 172 | 148 | 112 | 172 | 152 | 120 | 152 | 144 | 120 |
| | | kgf/cm ² | 1755 | 1510 | 1142 | 1754 | 1550 | 1224 | 1550 | 1469 | 1224 |
| 总功率 | TOTAL POWER | kW | 137 | | | 159 | | | 209 | | |

本公司保留修改技术参数的权利，恕不另行通知。 We reserve the right to change specifications without prior notice.

机器外形尺寸图 OVERALL DIMENSIONS

单位: mm

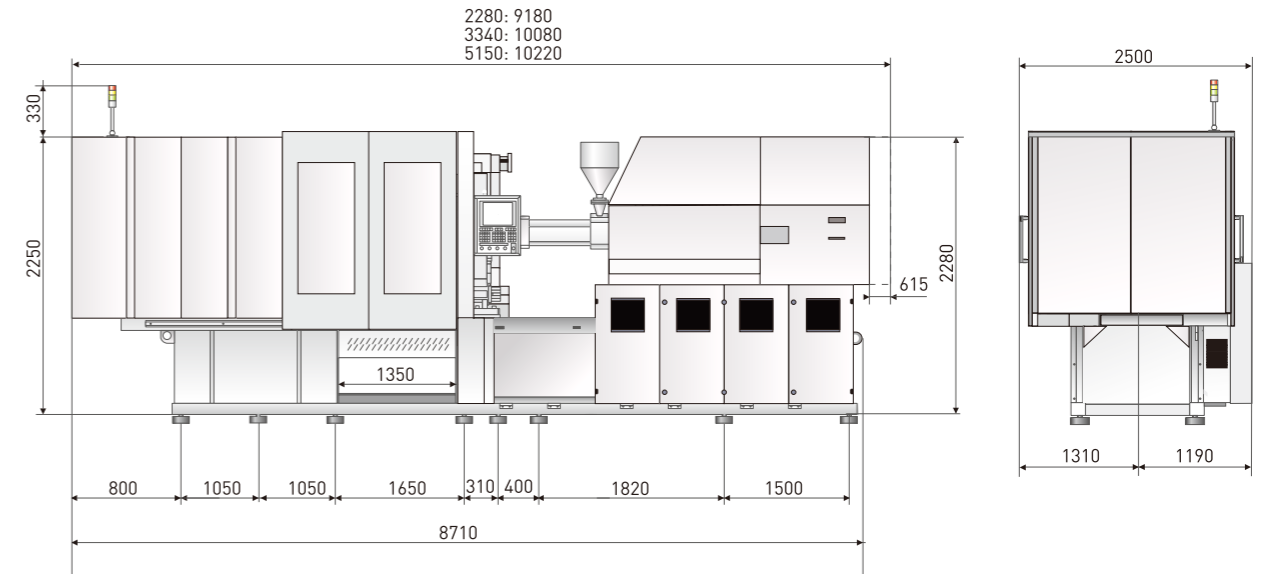

模板尺寸图 PLATEN DIMENSIONS

单位: mm

