Stack series LFP Battery

SUN-STA-30048-1P

SUN-STA-30048-2P



About This Manual

The manual mainly describes the product information, guidelines for installation, operation, and maintenance. The manual cannot include complete information about the solar photovoltaic-energy storage hybrid system.

How to Use This Manual

Read the manual and other related documents before performing any operation on the battery. Documents must be stored carefully and be always available.

Content may be updated or modified periodically due to product update iterations. The manual is subject to change without prior notice.

1. Safety Introductions



Reminding

1. It is very important and necessary to read the user manual carefully (in the accessories) before installing or using battery. Failure to do so or to follow any of the instructions or warnings in this document can result in electrical shock, serious injury, or death, or can damage battery, potentially rendering it inoperable.
2. If the battery is stored for long time, it is required to charge them every six months, and the SOC should be no less than 50%.
3. Battery needs to be recharged within 48 hours after fully discharged.
4. Do not expose cable outside.
5. All the battery terminals must be disconnected for maintenance.
6. Please contact the supplier within 24 hours if there is something abnormal.
7. Do not use cleaning solvents to clean battery.
8. Do not expose battery to flammable or harsh chemicals or vapors.
9. Do not paint any part of Battery, include any internal or external components.
10. Do not connect battery with PV solar wiring directly.
11. The warranty claims are excluded for direct or indirect damage due to items above.
12. Any foreign object is prohibited to insert into any part of battery.



Li-ion





Warning

1.1 Before Connecting

- 1) After unpacking, please check product and packing list first, if product is damaged or lack of parts, please contact with the local retailer.
- 2) Before installation, be sure to cut off the grid power and make sure the battery is in the turned-off mode.
- 3) Wiring must be correct, do not mistake the positive and negative cables, and ensure no short circuit with the external device.
- 4) It is prohibited to connect the battery and AC power directly.
- 5) Battery system must be well grounded and the resistance must be less than 1Ω .
- 6) Please ensured the electrical parameters of battery system are compatible to related equipment.
- 7) Keep the battery away from water and fire.

1.2 In Using

- 1) If the battery system needs to be moved or repaired, the power must be cut off and the battery is completely shut down.
- 2) It is prohibited to connect the battery with different type of Battery.
- 3) It is prohibited to put the batteries working with faulty or incompatible inverter.
- 4) It is prohibited to disassemble the battery.
- 5) In case of fire, only dry fire extinguishers can be used. Liquid fire extinguishers are forbidden.
- 6) Please do not open, repair, or disassemble the battery except staffs from MANYI or authorized by MANYI. We do not undertake any consequences or related responsibility which because of violation of safety operation or violating of design, production, and equipment safety standards.

2. Introduction

- SUN-STA-30048-1P~2P lithium iron phosphate battery is one of new energy storage products developed and produced by MANYI, it can be used to support reliable power for various types of equipment and systems.
- SUN-STA-30048-1P~2P is especially suitable for application scene of high power, limited installation space and long cycle life.
- SUN-STA-30048-1P~2 has built-in BMS battery management system, which can manage and monitor cells information including voltage, current and temperature. What' s more, BMS can balance cells charging and discharging to extend cycle life.
- Multiple batteries can connect in parallel to expand capacity and power in parallel for larger capacity and longer power supporting duration requirements.

2.1 Product Features

- 1) The whole module is non-toxic, non-polluting, and environmentally friendly.
- 2) Cathode material is made from LiFePO₄ with safety performance and long cycle life.
- 3) Battery management system (BMS) has protection functions including over-discharge, over-charge, over-current and high & low temperature.
- 4) The system can automatically manage charge and discharge state and balance current and voltage of each cell.
- 5) Flexible configuration, multiple battery modules can be in parallel for expanding capacity and power.
- 6) Adopted self-cooling mode rapidly reduced system entire noise.
- 7) The module has less self-discharge, up to 6 months without charging it on shelf, no memory effect, excellent performance of shallow charge and discharge.
- 8) Battery module communication address auto networking, easy maintenance, support remotely monitoring and upgrade the firmware.
- 9) High-power density: flat design, wall-mounted and floor-mount, saving installation space.

2.2 Product Overview

This section details the front and side panel of the interface functions.

RW-M6.1-B Product Interface

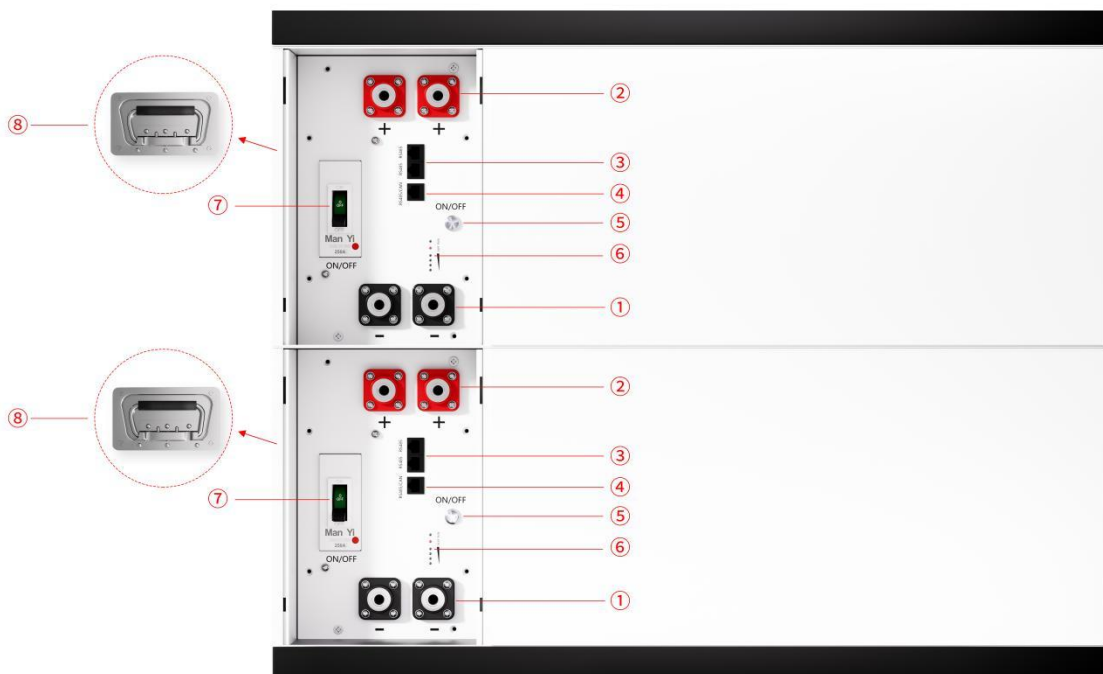

1. Battery negative	7. DC Breaker
2. Battery positive	8. Foldable handle
3.Parallel communication RS485	
4. Inverter CAN/RS485	
5.Power switch	
6. Battery indicators (RUN, ALM, SOC)	



Power Switch 

Power Switch: to turn ON/OFF the whole battery BMS standby, no power output. 

Battery positive

Used to connect Inverter positive terminals , Connect using the red plug in the accessory pack. 

Battery negative

Used to connect Inverter negative terminals , Connect using the black plug in the accessory pack. 

RUN

RUN LED: 1 green LED lighting to show the battery running status

ALM

Alarm LED: 1 red LED lighting to show the battery is under protection.

SOC 

SOC LED: 5 green LEDs to show the battery's current capacity.

Inverter communication terminal: (RJ45 port) follow the CAN protocol, used to output battery information to the inverter.

Definition of PCS Port Pin

No.	PCS Port Pin
1	485-B
2	485-A
3	--
4	CANH
5	CANL
6	--
7	485-A
8	485-B



Parallel Communication Terminal: (RJ45 port) Connect "RS485" Terminal of Previous battery for communication between multiple parallel batteries.

Definition of IN Port Pin

No.	PCS Port Pin
1	CANL
2	CANH
3	DI+
4	DI-
5	DI-
6	DI+
7	CANH
8	CANL



LED Status Indicators Instructions

RUN LED, green, long lighting when charging and blink when discharging.

ALM LED, red, long bright if equipment protected.

SOC LED, Battery capacity indicator, 5 green LED, each light represents 20% capacity.

Condition	RUN	ALM	SOC1	SOC 2	SOC 3	SOC 4	SOC 5
Power off	off						
Charge	█ Blink	off	█ Show SOC & highest LED blink				

Discharge or Idle		off	Show SOC & long bright
Alarm		off	Other LEDs are same as above.
System error/Protect		●	
Upgrade			Blink Fastly
Critical Error			Blink Slowly

DC Circuit Breaker

In the circuit for switching, breaking and bearing the rated working current, and can be in the line overload, short circuit, under voltage in the case of reliable protection.



BMS function:

Protection and Alarm	Management and Monitor
Charge/Discharge End	Intelligent Protect Mode
Charge Over Voltage	Intelligent Charge Mode
Discharge Under Voltage	Protect, Charge Current Limit
Charge/Discharge Over Current	Intelligent Protect Mode
High/Low Temperature(cell/BMS)	Intelligent Protect Mode
Short Circuit	Protect

2.3 Product Size

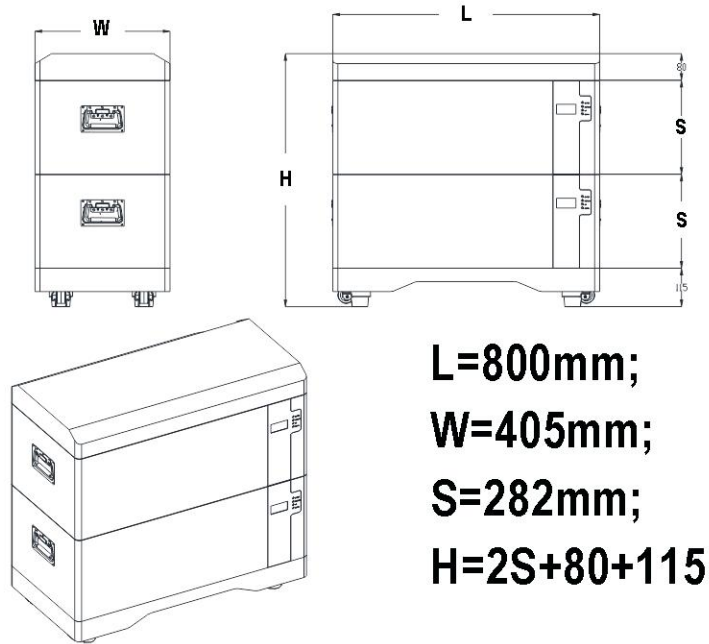

2.4 Technical Data

Model		SUN-STA-30048-1P	SUN-STA-30048-2P
Battery Chemistry		LiFePO4	
Capacity		300Ah	600Ah
Nominal Voltage		51.2V	
Energy		15kWh	30kWh
Charge/Discharge Current	Recommend	100	200
	Max.	200	400
Recommend Depth of Discharge		90%	
Dimension		800 * 405 * 477mm	800 * 405 * 759mm
Net Weight		120kg	230kg
Life Cycles		10000 times	
Active Balance		2A	
Build-in Circuit Breaker		250A	
Max. Output Power		10.24KW	20.48KW
Working Temperature		Charge: 0°C ~ +55°C Discharge: -20°C ~ +55°C	
Communication Port		CAN, RS485	

2.5 Product application solutions

The following illustration shows basic application of this battery.

It also includes following devices to have a complete running system.

- Generator or Utility
- PV modules
- Hybrid Inverters (Charge & Discharge)

Consult with your system integrator for other possible system architectures depending on your requirements.

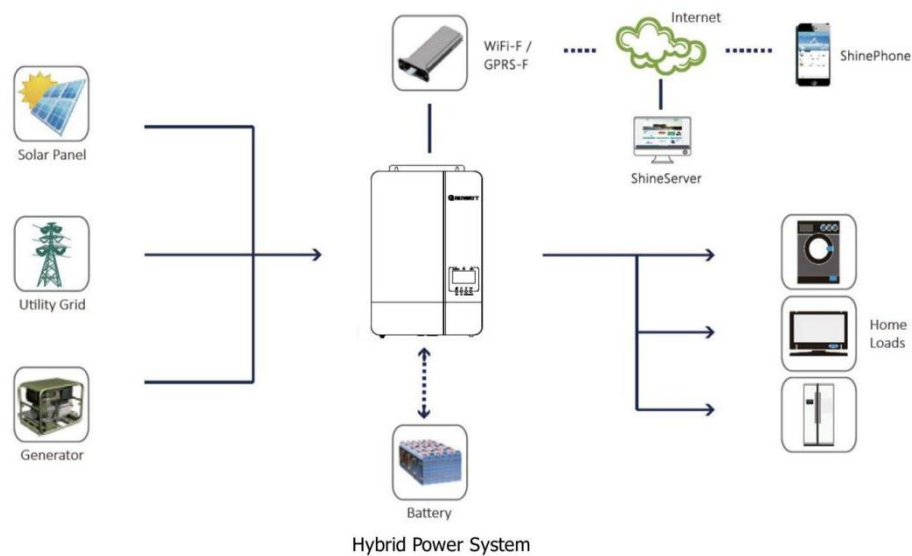













The picture is only an effect picture, please refer to the actual product, the final interpretation right belongs to MANYI.

3. Preparations for Installation

3.1 Explanation of Symbol

DANGER/HIGH VOLTAGE INSIDE



CAUTION:

- Do not disassemble or alter the battery in any way.
- Do not use the battery for purposes not described in its documentation.
- Do not drop, strike, puncture, or step on the battery.
- In case of electrolyte leakage, keep leaked electrolyte away from contact with eyes or skin, immediately clean with water and seek help from a doctor.
- Do not put the battery into a fire. Do not use it or leave it in a place near fire, heaters, or high temperature sources.
- Do not submerge the battery in water, or expose it to moisture.
- Do not allow the terminals to contact exposed wire or metal.
- The battery is heavy and can cause injury if not handled safely.
- Keep out of reach of children or animals.

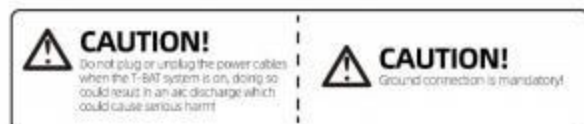

3.2 Tools

These tools are required to install the battery.



Torque Screwdriver



Phillips Screwdriver



Hexagon Wrench



Phillips Screwdriver



Slotted Screwdriver



Torque Wrench



Tape Measure



Driller



Pencil or Marker

NOTE:

Use properly insulated tools to prevent accident tale electric shock or short circuits.

If insulated tools are not available, cover the entire exposed metal surfaces of the available tools, except their tips, with electrical tape.

3.3 Safety Gear

It is recommended to wear the following safety gear when dealing with the battery pack.



Safety gloves



Safety goggles



Safety shoes

4. Instructions

4.1 Installation Precaution

Please avoid direct sunlight, rain exposure, snow laying up during installation and operation.

Please make sure the installation site meets below conditions:

- Not in direct sunlight.
- Not in areas where highly flammable materials are stored.
- Not in potential explosive areas.
- Not in the cool air directly.
- Not higher than altitude of about 2000 meters above sea level.
- Not in environment of precipitation or humidity (>95%).

4.2 Installation Location

Make sure that the installation location meets the following conditions:

- Indoor installation.
- The area is completely water proof.
- There are no flammable or explosive materials.
- The ambient temperature is within the range from -20°C to 50°C.
- The temperature and humidity are maintained at a constant level.
- There is minimal dust and dirt in the area.
- The distance from heat source is more than 2 meters.
- The distance from air outlet of inverter is more than 0.5 meters.
- Do not cover or wrap the battery case or cabinet.
- Do not place at a children or pet touchable area.
- The installation area shall avoid of direct sunlight.
- There are no mandatory ventilation requirements for battery module, but please avoid of installation in confined area. The aeration shall avoid of high salinity, humidity, or temperature.
- The product should be installed in a good ventilated environment, not in a confined space.



CAUTION

If the ambient temperature is outside the operating range, the battery pack stops operating to protect itself. The optimal temperature range for the battery pack to operate is 15°C to 35°C. Frequent exposure to harsh temperatures may deteriorate the performance and life of the battery pack.

4.3 DC connection

When using the product in parallel, use the BCable wiring harness . Connect the B+ between the battery pack with red wiring harness, connect the B- with black wiring harness, and connect the RS485 port of the first battery pack with the RS485 port of the next battery pack with communication cable.

When connecting inverter, the PCable is used. Inverter DC+ is connected to battery pack P+ with red wiring harness, Inverter DC- is connected to battery pack P- with black wiring harness, and the CAN/RS485 port of the battery pack is connected to the BMS communication port of the inverter.

5 Batteries in parallel

5.1 mode 1 (It is suitable for scenarios where the inverter power $\leq 10\text{kW}$)



It should be noted that the maximum current of the first battery is 200A (inverter power must not exceed 10kW), exceeding 200A will cause heating of the connectors and cable, and in severe cases, it will cause a fire accident.

If the inverter power exceeds 10kW, the parallel mode must be used mode 2!

Schematic diagram of parallel connection of low-power system batteries:

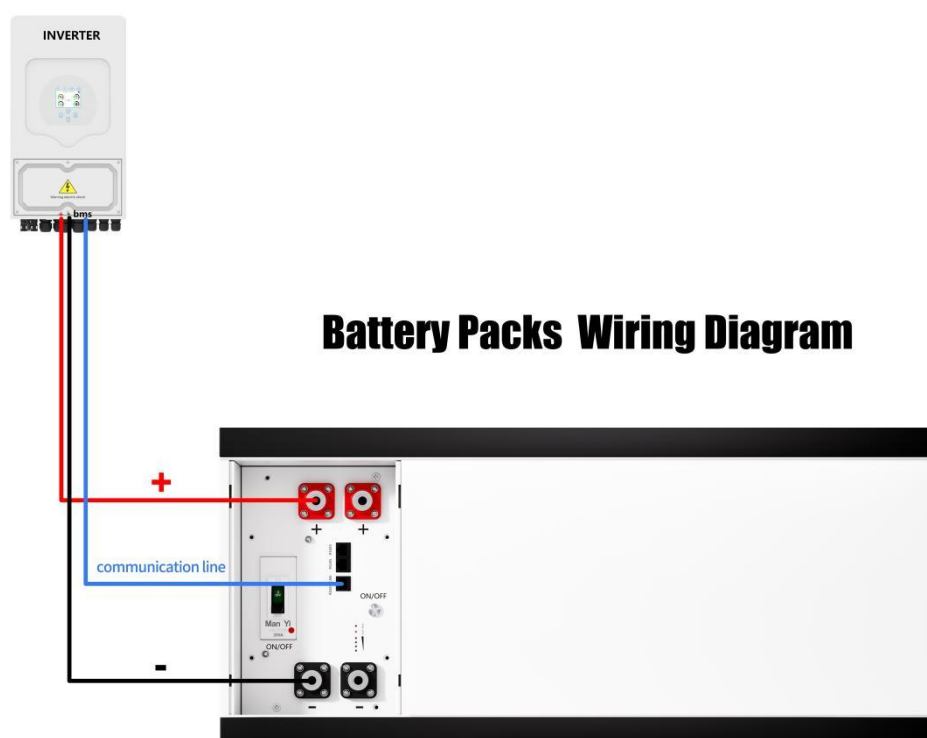

5.2 Parallel mode 2 (It is suitable for scenarios where the inverter power > 10kW)

Parallel connection:

Two batteries are connected in parallel, with one end connected to the positive and negative poles of the other battery pack, the positive pole connected to the positive pole, and the negative pole connected to the negative pole. A network cable is used to connect the RS485 communication interface of one battery pack, and the other end connected to the RS485 communication port of the other battery pack. The battery connected to RS485

communication is the first battery, the battery connected to RS485 communication is the second battery, and so on.

Schematic diagram of parallel connection of high-power system batteries:

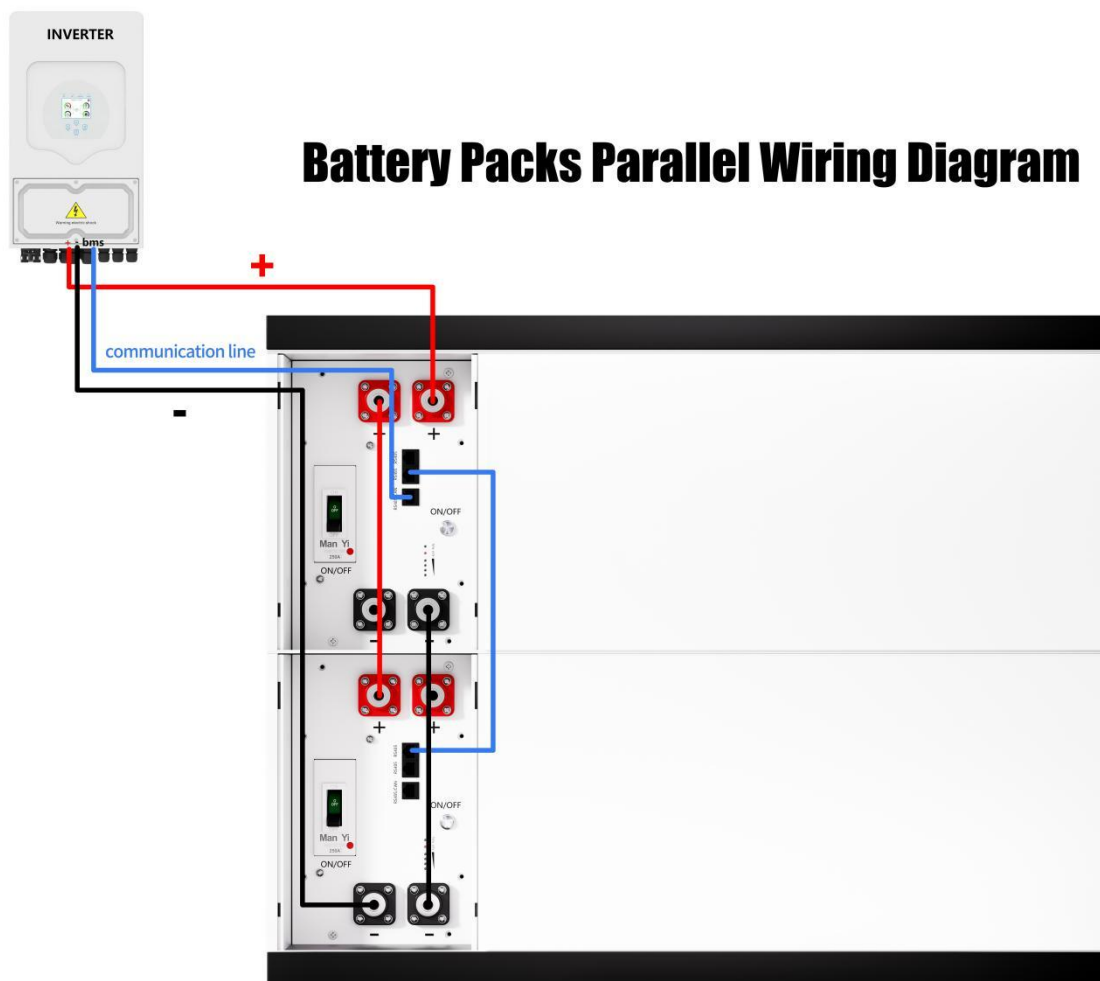

5.3 Visual Inspection of the Connection

After connecting the battery, check for:

- Usage of positive and negative cables.
- Connection of the positive and negative terminals.
- All the bolts are tightened.
- Cables fixation and the appearance.
- The installation of the protecting cover.

5.4 System startup and shutdown

Power on steps:

After installation, wiring, and configuration, you must check all connections. When the connection is correct.

- ① Turn on the Inverter switch.
- ② Turn on the battery module circuit breaker
- ③ Press the power button to activate the battery, If the green indicator on the front panel of the battery blinks, the battery system is normal.
- ④ Complete boot.

Power down steps:

- ① Press the battery module button.
- ② Turn off the battery module circuit breaker.
- ③ Finally, turn off the Inverter switch.
- ④ Complete shutdown

6. Inspection, Cleaning and Maintenance

6.1 General Information

- The battery product is not fully charged. It is recommended that the installation be completed within 3 months after arrival; During the maintenance process, do not re-install the battery in the battery product. Otherwise, the performance of the battery will be reduced;
- It is forbidden to dismantle any battery in the battery product, and it is forbidden to dissect the battery;
- After the battery product is over-discharged, it is recommended to charge the battery within 48 hours. The battery product can also be charged in parallel. After the battery product is connected in parallel, the charger only needs to connect the output port of any product battery.

- Never attempt to open or dismantle the battery! The inside of the battery does not contain serviceable parts.
- Disconnect the Li-Ion battery from all loads and charging devices before performing cleaning and maintenance activities
- Place the enclosed protective caps over the terminals before cleaning and maintenance activities to avoid the risk of contacting the terminals.

6.2 Inspection

- Inspect for loose or damaged wiring and contacts, cracks, deformations, leakage, or damage of any other kind. If damage to the battery is found, it must be replaced. Do not attempt to charge or use a damaged battery. Do not touch the liquid from a ruptured battery.
- Regularly check the battery' s state of charge. Lithium Iron Phosphate batteries will slowly self-discharge when not in use or whilst in storage.
- Consider replacing the battery with a new one if you note either of the following conditions:
 - - The battery run time drops below 70% of the original run time.
 - - The battery charge time increases significantly.

6.2 Cleaning

If necessary, clean the Li-Ion battery with a soft, dry cloth. Never use liquids, solvents, or abrasives to clean the Li-Ion battery.

6.3 Maintenance

The Li-Ion battery is maintenance free. Charge the battery to approximately > 80% of its capacity at least once every year to preserve the battery's capacity.

6.4 Storage

- The battery product should be stored in a dry, cool, and cool environment;
- Generally, the maximum storage period at room temperature is 6 months. When the battery is stored over 6 months, it is recommended to check the battery voltage. If the voltage is higher than 51.2V, it can continue to store the battery. In addition, it is needed to check the voltage at least once a month until the voltage is lower than 51.2V. When the voltage of the battery is lower than 51.2V, it must to be charged according to the charging strategy.
- The charging strategy is as follows: discharge the battery to the cutoff voltage with 0.2C current, and then charge with 0.2C current for about 3 hours. Keep the SOC of the battery at 40% -60% when stored;
- When the battery product is stored, the source of ignition or high temperature should be avoided and it should be kept away from explosive and flammable areas.

7. Troubleshooting

To determine the status of the battery system, users must use additional battery status monitoring software to examine the protection mode. The detailed information about the battery can be viewed by the specialized software of the upper computer. Monitor battery information by connecting the Inverter, connecting the battery in lithium battery mode, and viewing battery details on the Inverter display. Once the user knows the protection mode, refer to the following sections for solutions.

Table 7-1: Troubleshooting

Fault Type	Fault Generation condition	Possible Causes	Troubleshooting
BMS fault	<p>The cell voltage sampling circuit is faulty.</p> <p>The cell temperature sampling circuit is faulty</p>	<p>The welding point for cell voltage sampling is loose or disconnected.</p> <p>The voltage sampling terminal is disconnected.</p> <p>The fuse in the voltage sampling circuit is blown.</p> <p>The cell temperature sensor has failed.</p>	Replace the battery.
Electrochemical cell fault	The voltage of the cell is low or unbalanced.	<p>Due to large self- discharge, the cell over discharges to below 2.0V after long term storage.</p> <p>The cell is damaged by external factors, and short circuits, pinpricks, or crushing occur.</p>	Replace the battery.
Overvoltage protection	<p>The cell voltage is greater than 3.65 V in charging state.</p> <p>The battery voltage is greater than 58.4 V.</p>	<p>The busbar input voltage exceeds the normal value.</p> <p>Cells are not consistent. The capacity of some cells deteriorates too fast or the internal resistance of some cells is too high.</p>	If the battery cannot be recovered due to protection against abnormality contact local engineers to rectify the fault.
Under voltage protection	<p>The battery voltage is less than 40V.</p> <p>The minimum cell voltage is less than</p>	<p>The mains power failure has lasted for a long time.</p> <p>Cells are not consistent. The capacity of some cells</p>	Same as above.

	2.5V	deteriorates too fast or the internal resistance of some cells is too high.	
Charge or discharge high temperature protection	The maximum cell temperature is greater than 60°C	The battery ambient temperature is too high. There are abnormal heat sources around	Same as above.
Charge low temperature protection	The minimum cell temperature is less than 0°C	The battery ambient temperature is too low.	Same as above.
Discharge low temperature protection	The minimum cell temperature is less than -20°C	The battery ambient temperature is too low.	Same as above.

By checking the above data and sending the data to the service personnel of our company, the service personnel of our company will reply the corresponding solution after receiving the data.

8. Transportation Requirements

The battery products should be transported after packaging and during the transportation process, severe vibration, impact, or extrusion should be prevented to prevent sun and rain. It can be transported using vehicles such as cars, trains, and ships.

Always check all applicable local, national, and international regulations before transporting a Lithium Iron Phosphate battery.

Transporting an end-of-life, damaged, or recalled battery may, in certain cases, be specially limited or prohibited.

The transport of the Li-Ion battery falls under hazard class UN3480, class 9. For transport over water, air and land, the battery falls within packaging group PI965 Section I.

Use Class 9 Miscellaneous Dangerous Goods and UN Identification labels for transportation of lithium-ion batteries which are assigned Class 9. Refer to relevant transportation documents.



Figure 9-1: Class 9 Miscellaneous Dangerous Goods and UN Identification Label

9. Compatible with inverter modules

Manyi BMS Compatible Inverter List (If the inverter is not on the list, do not hesitate to get in touch with our engineer)							
Brand of Inverter	Protocol Agreements	Ports	Baud Rate	Verified Inverter Model	Protocol Switching	Protocol Version	
Pylontech	PYLONTECH	CAN-Bus-protocol-PYLON	CAN	500K	All PYLONTECH CAN	PN-GDLT	V1.3
Pylontech	PYLONTECH	RS485-protocol-pylon-low-voltage	485	9600	PYLONTECH 485 Protocol inverter3K	Automatic Adaptation	V3.5
Goodwe	固德威 GOODWE	GOODWE Protocol	CAN	500K	GW3648D-ES	PN-GDLT	V1.5
Solis	德业 solis	CAN communication protocol	CAN	500K	RHI-5K-48ES Solis_EO_5G_ENX S5-EO1P5K-48-P S6-EH1P6K-L-EN	GINL	V1.0
Sungrow	阳光电源 SUNGROW	CAN-Bus-protocol-PYLON	CAN	500K	SH5K-30	PN-GDLT	V1.3
CHNT	CHNT POWER	Chint+Power CAN bus protocol V1.0 .0	CAN	500K	CPS SCE6KTL-120/EU	PN-GDLT	V1.0
Sofar	SOFAR 首航新能源	SOFAR BMS Protocol CAN	CAN	500K	HYD 3000-ES	SMA-SF	V1.0
Growatt-SPF	Growatt	Growatt BMS CAN-Bus-protocol-low-voltage	CAN	500K	SPF 5000TL HVM-WPV-P SPF 5/6/8/10KT HVM	GRWT	V1.05
Growatt-SPF	Growatt	Growatt BMS communication protocol of growatt low voltage battery	CAN	500K	Growatt SPH 5000	GRWT	V1.01
SMA	SMA	FSS-ConnectingBat-TI-en-20W	CAN	500K	SI6.0,SI8.0H-13	SMA-SF	V2.0
Victron	victron energy	can-bus_bms_protocol	CAN	500K	MultiPLUS-II	VCTR	V1.0
Lux Power	LUPOPOWER™	Luxpowertek Battery CAN Protocol	CAN	500K	SNA5000 WPV LXP6K	PN-GDLT	V1.0
Sol-Ark	Sol-Ark	Sol-Ark CAN Bus Protocol	CAN	500K	Sol-Ark 8K & 12K	PN-GDLT	V1.2
Studer	Studer	Technical specification Studer BMS Protocol	CAN	500K	XTM 4000-48	Studer	V1.03
TBB	TBB POWER	TBB BMS CAN Protocol V1.02	CAN	500K	Riio Sun 5KVA-S CA 3090L	PN-GDLT	V1.02
Deye	德业 Deye	CAN-Bus-protocol-PYLON-v1.3	CAN	500K	SUN-3 6KSG03LP1-EU SUN-10/12K-SG04LP3-EU	PN-GDLT	V1.0
Sunsynk	SUN SYNK	CAN-Bus-protocol-PYLON	CAN	500K	SUN-3K-SG04LP1-24-EU SUN-3.6/5/6K-SG04LP1-EU	PN-GDLT	V1.3
LIVOLTEK	LIVOLTEK	LIVOLTEK CANBUS Protocol of Low Voltage SystemV1.0	CAN	500K	GF1-3K48S1 GF1-5K48S1	PN-GDLT	V1.0
SOROTEC	SOROTEC Power Solutions Experts	2_CAN Protocol 1.0	CAN	500K	REVO III 5.5-8KVA	PN-GDLT	V1.0
MEGAREVO	MEGAREVO	MEGAREVO_5K_BMS V1.01	CAN	500K	REVO_RKL1 R8KLN R5KL1	PN-GDLT	V1.01
AFORE	Afore	Luxpowertek Battery CAN Protocol	CAN	500K	AF(1-6K)-SL	PN-GDLT	V1.0
SACOLAR	Sacolar	Growatt BMS CAN-Bus-protocol-low-voltage	CAN	500K	SP Series	GRWT	V1.05
MUST	MUST	CAN-Bus-protocol-PYLON	CAN	500K	PV1800 Pro Series (3/5.2KW)	PN-GDLT	V1.3
INVT	invt	CAN-Bus-protocol-PYLON	CAN	500K	INVT iMarsXD6KTL	PN-GDLT	V1.3
RENAC	RENAC	CAN-Bus-protocol-PYLON	CAN	500K	Renac-ESC5000-DS	PN-GDLT	V1.3
Lu	欧陆电气 OLU	CAN-Bus-protocol-PYLON	CAN	500K	OLU5048GII	PN-GDLT	V1.3
Hinen	hinen	CAN-Bus-protocol-PYLON	CAN	500K	Hinen-SH6KL	PN-GDLT	V1.3
SRNE	srne	PACE BMS Modbus Protocol for RS485	485	9600	HF4850S80-H HF4850S80-145 HF2430S60-100 HES4855S100-H	Automatic Adaptation	V1.3
DEYE	德业 Deye	RS485-protocol-pylon-low-voltage	485	9600	SUN-3 6KSG03LP1-EU SUN-10/12K-SG04LP3-EU	Automatic Adaptation	V1.0
Growatt-SPF	Growatt	SPF BMS RS485	485	9600	SPF 5000TL HVM-WPV-P SPF 10KT HVM	Automatic Adaptation	V2.01
SMK SOLAR	SMK SOLAR 斯曼科新能源	GT 1.0	485	9600	Glory M5000 HHP-48L	Automatic Adaptation	V2.01
Voltronic	Voltronic Power	Voltronic Inverter and BMS 485 communication protocol	485	9600	InfiniSolar VII GSDHW VIV-6KW	Firmware Upgrade	V1.0
EASUN	EASUN POWER	Voltronic Inverter and BMS 485 communication protocol	485	9600	IGrid SV IV 5.6KW	Firmware Upgrade	V1.0
MPP Solar	MPP Solar	Voltronic Inverter and BMS 485 communication protocol	485	9600	MPI WP 12_15KW	Firmware Upgrade	V1.0
EPEVER	EPEVER 汇能锂电	V1.4.pdf	485	9600	UP5000-HM8042	Automatic Adaptation	V1.4
Bentterson	Bentterson	RS485-protocol-pylon-low-voltage-	485	9600	SAL 3.5KW-UL SAL 5KW-EU	Automatic Adaptation	V1.0
Xindun	xindun 鑫顿锂电	SPF BMS RS485 Protocol	485	9600	LS-T50248-W60 HP-pro50248	Automatic Adaptation	V2.01
Techfine	Techfine	RS485-protocol-pylon-low-voltage	485	9600	GB5548JMh	Automatic Adaptation	V1.0