

Flaglite 

FL200x | FL200Lx

User Manual

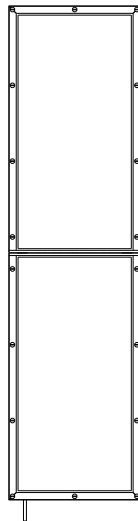
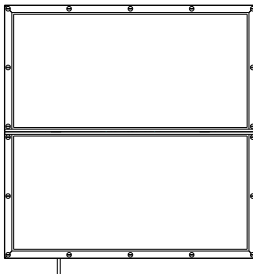

1.Introduction

Thank you for purchasing the Flaglite series LED panel light.

-- FL200X/FL200LX

The Lishuai Flaglite series is a high-performance professional panel light designed by Lishuai Film and Television for high-end live streaming and commercial filming. The light has an ultra-thin thickness of 1.5cm and is the first to be foldable. It is lightweight, portable, and durable, with excellent performance. It has high brightness, high color rendering, and high-quality light sources, greatly improving the quality of the image.

In addition, our lighting system integrates with the new Light Reel APP, offering a wide range of options for live broadcast rooms and studio lighting. The APP provides precise stepless dimming from 0-100%, along with 11 built-in movie-level special effects and customizable function settings to cater to diverse scenes and significantly enhance work efficiency. With dual color temperature selection and various wireless light control methods, you can effortlessly explore stress-free creativity.

2. Warnings

1. Do not disassemble or modify the light.
2. Do not operate with wet hands, doing so may cause electric shock.
3. Do not operate in environments near flammable gases or volatile liquids as this may increase the risk of explosion/fire.
4. Do not operate in enclosed spaces where heat buildup can be extreme, such as a car on a sunny day. The increased heat may cause premature failure of the lighting unit.
5. Do not touch the plug or AC adapter with wet hands; doing so may cause electric shock.
6. Do not damage, disassemble, pull or twist the power cord, otherwise it may cause fire or electric shock.
7. Do not place under heavy objects.
8. Keep the light surface clean with a soft, dry cloth.
9. Use ONLY the provided AC power adapter; using other AC power adapters may result in damage to the light.
10. Do not forcefully collide with the LCD touch screen to avoid damage.
11. Avoid dust and debris buildup on the light surface as this will change illuminance and color temperature.
12. When using accessories please ensure that these are installed properly to avoid damage to the light or other safety issues caused by falling accessories.
13. Please loosen the adjustment & locking handle before adjusting the angle of the lamp body.

3. Standard Equipment List (please check and verify)

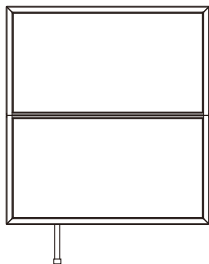

Light body
(1pc)

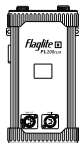

Control box
(1pc)



Softbox
(1pc)



3 meter
extension cable
(1pc)



AC power cord
(1pc)



Adapter plate
(1pc)



Double-female
stand mount adapter
(1pc)



Tube clamp
(1pc)



Carrying bag
(1pc)



Instruction
(1pc)

Tip: The illustrations in the manual are schematic diagrams and are for reference only. Since products are constantly updated and upgraded, if there is any discrepancy between the actual product and the diagram, please refer to the actual product.

4. Parts Identification (using FL200X as an example)

1. Light body:

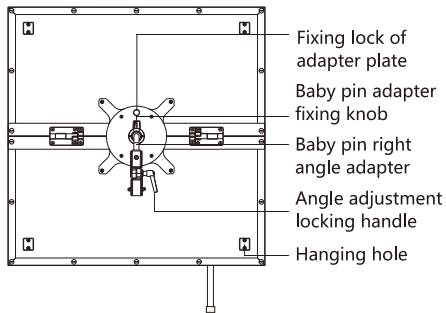
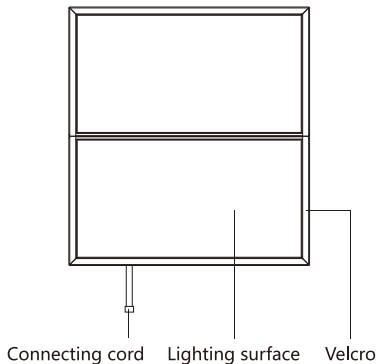

2.Control box:

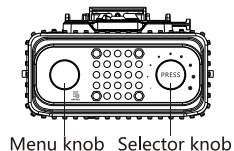
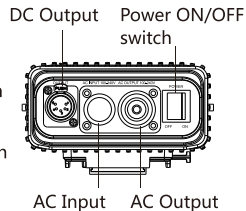
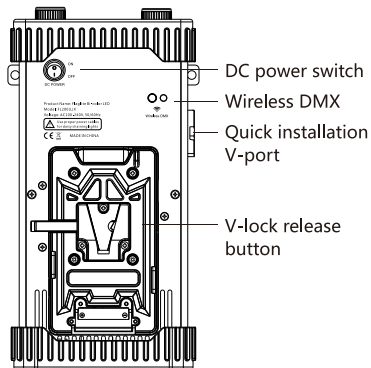
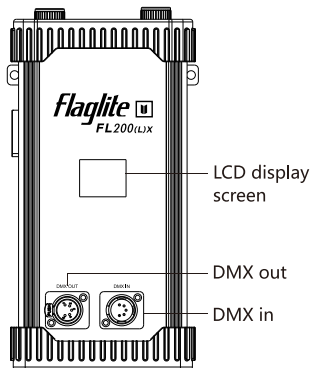

5.Usage

1.Assembly of adapter plate accessories

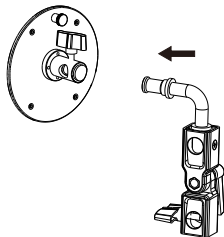

Connect the stand mount adapter to the round adapter plate, and tighten the adapter plate knob.

2. Fix the adapter plate and the lamp body

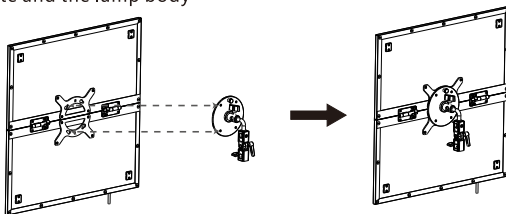

Align the assembled accessory bumps of the adapter plate with the holes on the fixing plate on the back of the lamp body, and turn it clockwise until a click sound is heard to indicate that it has been fixed; if you need to remove the adapter plate, just pull the adapter plate fixing lock outward, just rotate the adapter plate counterclockwise.

3.Installation of softbox

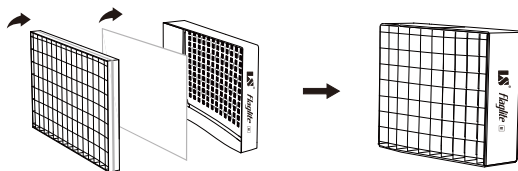

Align the hooked side of the Velcro on the soft box with the Velcro on the lamp body, then press the Velcro on the lamp body and soft box, and then install the diffuser and the grid.

4.Fix the light body

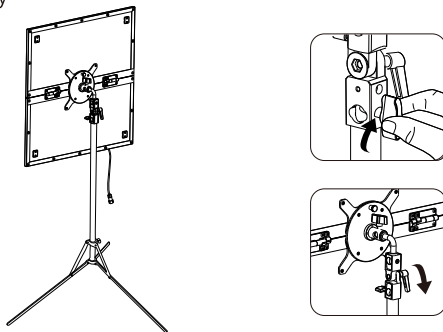

Insert one end of the stand mount adapter into the stand , tighten the knob, then adjust the angle locking handle to the desired angle.

5. Power supply

(1) AC power supply (single lamp)

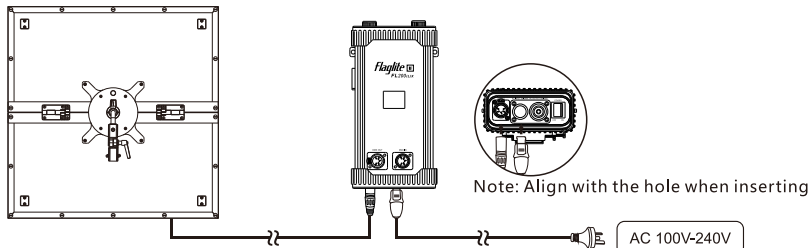

Insert the cable port of the lamp body into the port at the bottom of the control box, connect the control box to the power cord, and turn on the external power supply.

Note: If the lamp body connection cable is not long enough during use, you can use a standard 3-meter extension cable to extend it. Different types of extension cords must be used accordingly and cannot be mixed.

(2) AC power supply (multiple lights)

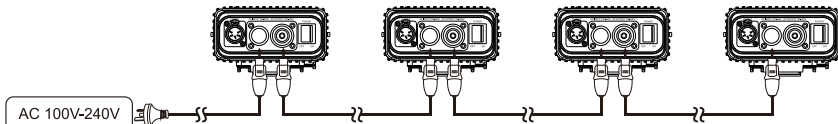

When multiple lights need to be powered by AC power, connect the AC input interface of the first control box to the external power supply, then use the control box cable (need to be purchased separately) to connect the AC input interface of the next control box through the AC output interface, and repeat the above operations. Multiple devices can be connected in sequence. For multi-light connection specifications, please refer to the table below.

Input voltage	Control box connection wire gauge	Number of control boxes (recommended maximum safe number)	Power cord gauge	power cord plug
AC100~120V	≥14AWG	6	≥14AWG	≥16A
	≥16AWG	4	≥16AWG	≥10A
AC200~240V	≥2.0square meters	12	≥2.0square meters	≥16A
	≥1.5square meters	8	≥1.5square meters	≥10A
	≥1.0square meters	4	≥1.0square meters	≥10A

(Note: The rated current of the male and female plugs used in the control box connection cable must be ≥16A)

(3)DC power supply

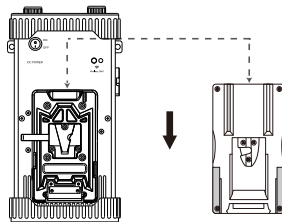

Note: When using external AC power supply, please turn off the DC power switch, otherwise it may cause damage; battery usage range: 13-30V/15A, ≥180Wh.

6. Power on and turn on the power switch

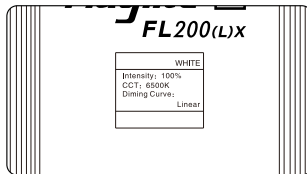
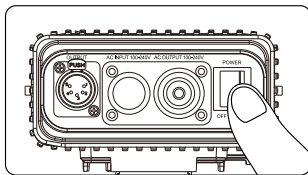

Turn on the power, turn on the power switch at the bottom of the control box, and the LCD screen of the control box will display a white light interface.

7. White light mode

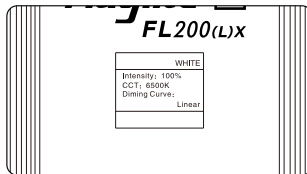
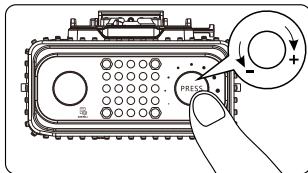

Rotate the menu knob to enter the white light interface. Short press the selector knob to switch between brightness, color temperature, and dimming curve modes. Rotate the selector knob to adjust the value. The brightness adjustment range is 0-100%, and the color temperature adjustment range is 2700K-6500K. The dimming curve options are Linear, Exponential, Logarithmic, and S-Curve, respectively.

8.FX mode

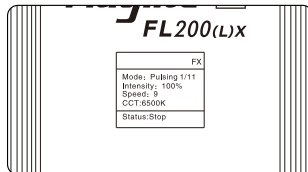
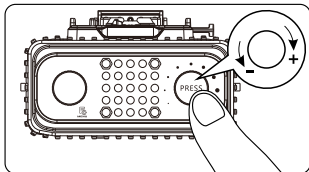

Rotate the menu knob to enter the special effects interface. Short press the selector knob to switch between mode, brightness, speed, color temperature, and status. Rotate the selector knob to adjust the value. Special effects mode range is 1-11, the brightness adjustment range is 0-100%, the speed adjustment range is 0-9, and the color temperature adjustment range is 2700K-6500K or warm white/neutral/cold white. The status bar includes run/stop.

9.DMX mode

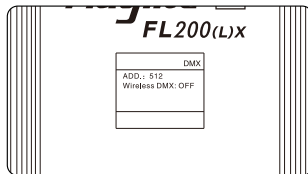
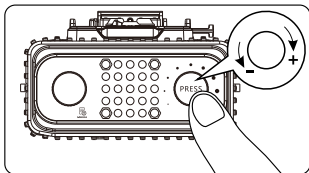

Rotate the menu knob to enter the DMX interface. Short press the multi-function knob to switch between address and wireless DMX. Rotate the selector knob to adjust the value. The address adjustment range is 1-512. The wireless DMX option is on and off.

(1)When using DMX, connect the DMX cable(to be purchased separately) to the console. Set up DMX address on the light to match the DMX console. Now the light is controlled by the DMX signal.

DMX connection for single light

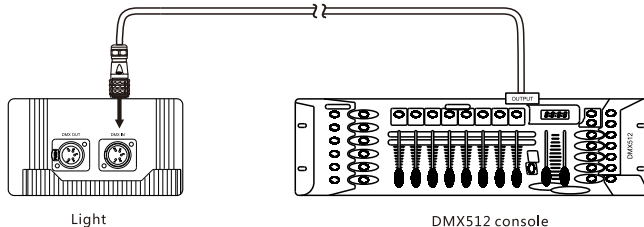

DMX connection for multiple lights

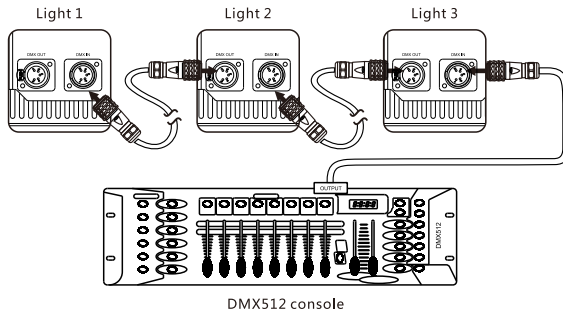

(2)DMX Control

a.Single color temperature light :

The brightness is the corresponding channel on the console, such as 1-1 brightness (1 channel), 1-2 brightness (2 channels), 1-3 brightness (3 channels)...

b.Dual color temperature light :

Brightness and color temperature are adjacent channels on the console. If 1-1 is brightness, then 1-2 is color temperature (1 channel); 1-2 represents brightness, 1-3 represents color temperature (2 channels)...

DMX Address Correspondence Table :

LCD display address	DMX console channels (single color temperature)	DMX console channels (Bi-color temperature)
1	1-1 (Brightness)	1-1 (Brightness) ,1-2 (Color Temperature)
2	1-2 (Brightness)	1-2 (Brightness) ,1-3 (Color Temperature)
.....
16	1-16 (Brightness)	1-16 (Brightness) ,2-1 (Color Temperature)
17	2-1 (Brightness)	2-1 (Brightness) ,2-2 (Color Temperature)
.....
511	32-15 (Brightness)	32-15 (Brightness) ,32-16 (Color Temperature)
512	32-16 (Brightness)	32-16 (Brightness) ,32-17 (Color Temperature)

(3) Wireless DMX Operation instructions

To use the wireless DMX function, short press the selector knob, adjust to the DMX settings interface and turn on the wireless DMX. Press the wireless DMX button on the upper right side of the control box. The indicator light displays the current ID value in color. Each time you press the wireless DMX button, the indicator light will cycle through the colors red, green, yellow, blue, purple, cyan, and white. The status of the wireless DMX indicator listed below.

Indicator working conditions	Signals receiving condition
Be continuously on	No wireless DMX signal
Green color flashes	Signal is being received

Note: To use the wireless DMX control function, please make sure the signal from the transmitter is the the same as the signal on the control box, means that the wireless DMX indicators on the control box and the transmitter show the same color.

Wireless DMX transmitter operation instructions(wireless DMX transmitter need to be purchased separately)

1) Connect the wireless transmitter to the DMX console, and power on the wireless transmitter.
2) Try to use a small stick to press the button of the wireless DMX transmitter, the indicator on it shows different colors of red, green, yellow, blue, purple, cyan and white. The different colors means different ID numbers. Make sure the color is the same as the indicator color on the control box. The working status of the wireless DMX transmitter is as below.

Indicator working conditions	Signals transmitting condition
Be continuously on	No wireless DMX signal
Red color flashes	Signal is being transmitted

10.Remote control Mode(remote control to be purchased separately)

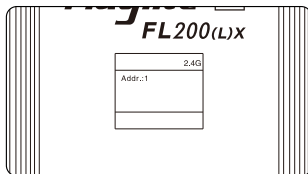
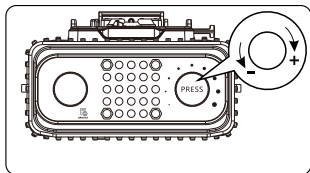

Rotate the menu knob to enter the remote control interface. Rotate the selector knob to adjust the address values. The remote control address adjustment range is 1-12, and the remote control address selection is synchronized with it.

Noted:RMT-OFF means that the remote control function can not be used.

11.Setting mode

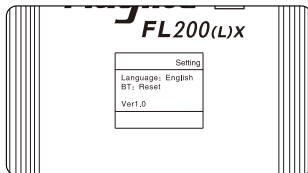
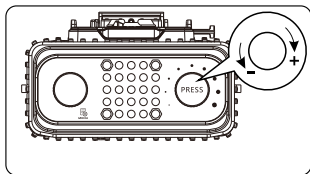

Rotate the menu knob to enter the settings interface. Short press the selector knob to switch between language and Bluetooth settings.

a.Language switching: Rotate the selector knob to switch between Chinese and English options.

b.Bluetooth settings: Before using the APP to control the lighting, rotate the selector knob to reset the Bluetooth of the lighting.

14.APP control



Light Reel User's Guide



APP download page

Users can search for "Light Reel" in the Appstore and Android market, or scan the QR code above to download the mobile APP to control the lighting of Lishuai Film and Television.

15.Firmware Upgrade

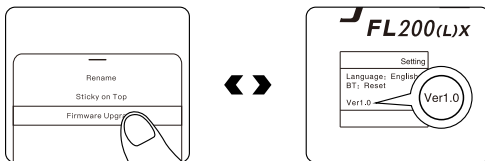

Users can upgrade their firmware through the Light Reel APP. After the upgrade is successful, they need to restart the lighting and enter the settings interface to view the current device version.

6.Product specifications

Product model	FL200X	FL200LX
Power	210W	
Beam angle	120°	
Color temperature	2700K-6500K	
CRI	Average 96	
TLCI	Average 98	
Rf	Average 94	
Rg	Average 103	
Working voltage	AC100V-240V 50/60Hz	
V-mount port battery output	13~30V	
V-mount battery compatibility	14.8V、16.8V Battery half power output ; 26V、28.8V Battery full power output ;	
Lighting size (unfolded)	605 x 605 x 25mm	1175 x 315 x 25mm
Liighting size (folded)	605 x 310 x 40mm	595 x 315 x 40mm
Control box size	144 x 85 x 272mm	
Lighting weight	3kg	
Control box weight	1.85kg	

FL200X Illuminance data

CCT	Distance	1m	2m	3m	4m	5m
	Data					
2700K	W/O reflector	6390 lux	1760 lux	820 lux	480 lux	320 lux
	W/Softbox	5040 lux	1340 lux	590 lux	350 lux	230 lux
3200K	W/O reflector	6670 lux	1840 lux	850 lux	490 lux	330 lux
	W/Softbox	5240 lux	1380 lux	610 lux	360 lux	240 lux
5600K	W/O reflector	7390 lux	2030 lux	940 lux	550 lux	360 lux
	W/Softbox	5980 lux	1550 lux	700 lux	410 lux	270 lux
6500K	W/O reflector	7580 lux	2100 lux	980 lux	570 lux	370 lux
	W/Softbox	6270 lux	1630 lux	710 lux	420 lux	280 lux

FL200LX Illuminance data						
CCT	Distance	1m	2m	3m	4m	5m
	Data					
2700K	W/O reflector	5800 lux	1710 lux	810 lux	470 lux	310 lux
	W/Softbox	3970 lux	1180 lux	560 lux	330 lux	220 lux
3200K	W/O reflector	5980 lux	1770 lux	830 lux	490 lux	320 lux
	W/Softbox	4160 lux	1250 lux	580 lux	340 lux	220 lux
5600K	W/O reflector	6610 lux	1960 lux	930 lux	540 lux	360 lux
	W/Softbox	4800 lux	1410 lux	660 lux	380 lux	250 lux
6500K	W/O reflector	6990 lux	2070 lux	970 lux	570 lux	370 lux
	W/Softbox	4990 lux	1450 lux	700 lux	390 lux	260 lux

Product specifications are based on testing our laboratory samples. The product may vary slightly, however these variations will not affect normal use. The design and specifications are subject to change without notice.



☎ 0574-62763333/62636368 📠 0574-62636398 ✉ ls@lishuai.com.cn

📍 No.55 East Zhenxing Road, Yuyao City Zhejiang Province, China