

**COOLCAM**

**P60G | P120G**

User Manual

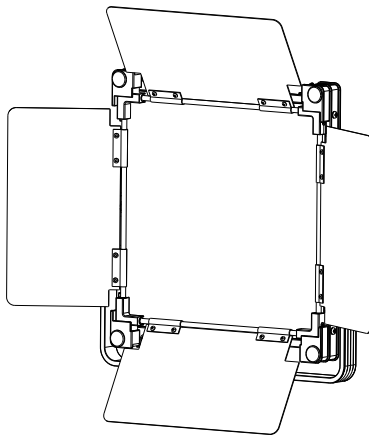

# 1.Introduction

Thank you for purchasing the Lishuai COOLCAM series of LED video lights. The LiShuai COOLCAM series products are the high-performance professional lights specially designed for high-end live streaming and commercial shooting.

The COOLCAMP60 **【G】** /P120 **【G】** light body is compact and lightweight yet delivers exceptional performance with high brightness, excellent color rendering, and a high-quality light source, significantly enhancing picture quality. Moreover, it comes with the new Light Reel APP, which provides more options for live streaming rooms and studio lighting. With 0-100% precise stepless dimming, 11 built-in movie grade special effects, it offers functional settings that cater to different scenarios and comprehensively improve work efficiency. It also features single or dual color temperature selection, wireless light control methods, which makes it easy to unleash your creativity without pressure.

## 2. Warnings

1. Do not disassemble or modify the light.
2. Do not operate with wet hands, doing so may cause electric shock.
3. Do not operate in environments near flammable gasses or volatile liquids as this may increase the risk of explosion/fire.
4. Do not operate in enclosed spaces where heat buildup can be extreme, such as a car on a sunny day. The increased heat may cause premature failure of the lighting unit.
5. Do not touch the plug or AC adapter with wet hands; doing so may cause electric shock.
6. Do not damage, disassemble, pull or twist the power cord, otherwise it may cause fire or electric shock.
7. Do not place under heavy objects.
8. Keep the light surface clean with a soft, dry cloth.
9. Use ONLY the provided AC power adapter; using other AC power adapters may result in damage to the light.
10. Do not forcefully collide with the LCD touch screen to avoid damage.
11. Avoid dust and debris buildup on the light surface as this will change illuminance and color temperature.
12. When using accessories please ensure that these are installed properly to avoid damage to the light or other safety issues caused by falling accessories.
13. Please loosen the adjustment & locking handle before adjusting the angle of the lamp body.

### 3. Standard Equipment List

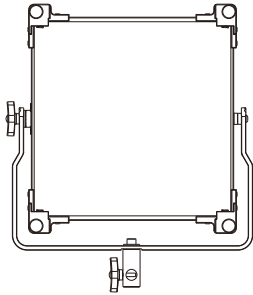

Light body  
(1pc)

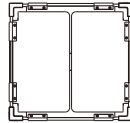

Barn door  
(1pc)



Power cord  
(1pc)



Power adapter  
(1pc)      bracket  
(1pc)



Instruction manual  
(1pc)

## 4. Parts Diagram ( Take P60 as an example )

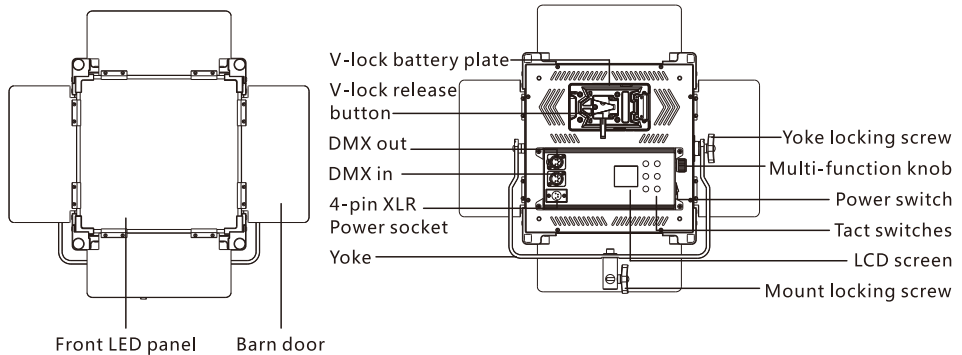

# 5.Operation Instructions

## 1.Light Installation

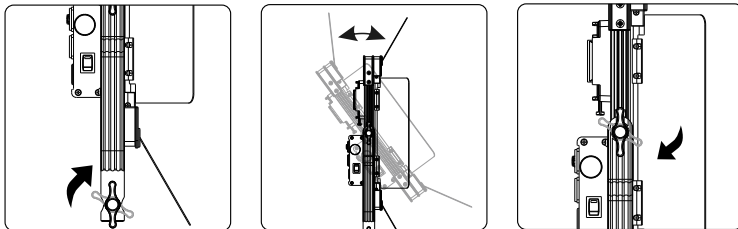

Tighten the stand mount locking screw to fix the light on the tripod, adjust the appropriate angle with the light handle, and then lock the locking handle clockwise.

## 2.Placing the power adapter

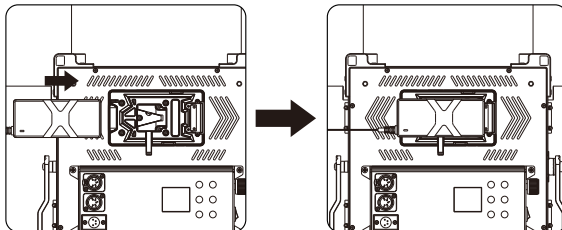

A bracket with V-lock holder is pre-installed on the AC power adapter. Install the power adapter with holder into the V-lock plate on the back of the light. It is successfully installed when you hear the locking mechanism click.

### 3.Power Supply

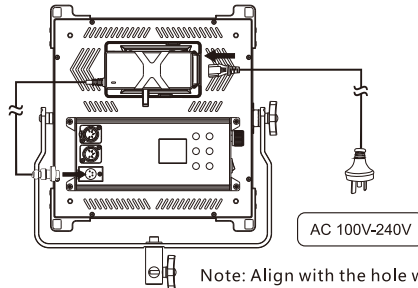

Connect the power adapter to the light fixture by inserting the power adapter plug into the DC power input socket in the lower left side of the light fixture. Connect the AC power cable to the external power supply (AC100-240V)

### 4.Power on and turn on the power switch

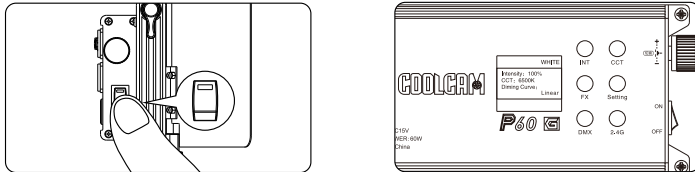

Press the power switch on the right side of the power control box, the light is on. The buttons on the control panels are for brightness, color temperature, special effects, settings, DMX and address.

## 5.White Mode

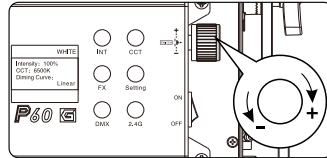
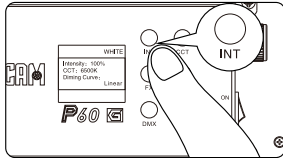

Press the brightness or CCT button to enter White interface, and short press the selector knob to switch between brightness ,color temperature and dimming curve modes. Rotate the selector knob to adjust the value, with a brightness adjustment range of 0-100% and a color temperature adjustment range of 2700K-6500K.Rotate the selector knob to switch between linear, exponential, logarithmic, and S-Curve.

## 6.FX Mode

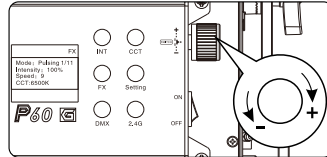
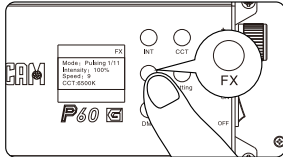

Press the FX button to enter the special effects interface and short press the selector knob to switch between mode, brightness, speed, and color temperature. To adjust the settings, rotate the selector knob to the desired value. The special effects mode range is from 1 to 11. The brightness adjustment range can be set from 0 to 100%. Adjust the speed with the selector knob within the range of 0 to 9. You can also adjust the color temperature by selecting between 2700K to 6500K, or by selecting warm white, neutral, or cold white.



## 7.DMX Mode

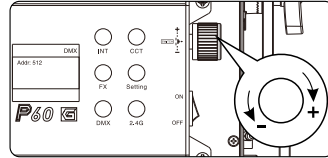
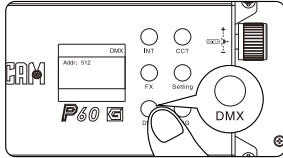

Press the DMX button to enter the DMX interface and rotate the selector knob to adjust the value, with an address adjustment range of 1-512.

(1)When using DMX, connect the DMX cable(to be purchased separately) to the console. Set up DMX address on the light to match the DMX console. Now the light is controlled by the DMX signal.

### DMX connection for single light

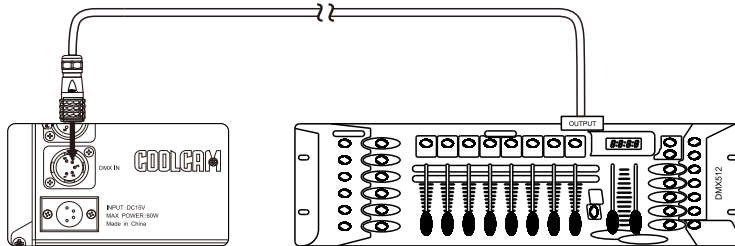

Light

DMX512 console

## DMX connection for multiple lights

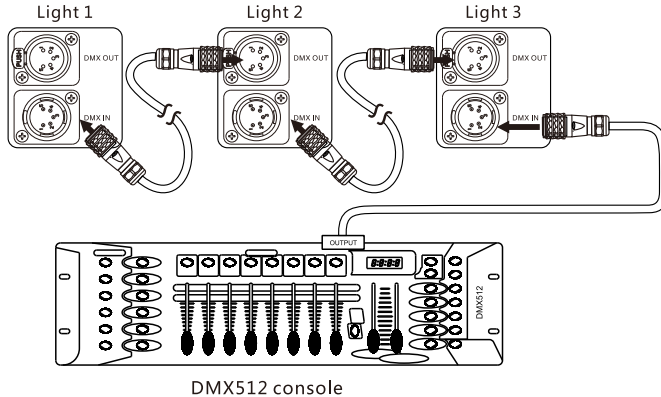

### (2)DMX Control

#### a.Single color temperature light :

The brightness is the corresponding channel on the console, such as 1-1 brightness (1 channel), 1-2 brightness (2 channels), 1-3 brightness (3 channels)...

#### b.Dual color temperature light :

Brightness and color temperature are adjacent channels on the console. If 1-1 is brightness, then 1-2 is color temperature (1 channel); 1-2 represents brightness, 1-3 represents color temperature (2 channels)...

DMX Address Correspondence Table :

LCD display address	DMX console channels (single color temperature)	DMX console channels (Bi-color temperature)
1	1-1 ( Brightness )	1-1 ( Brightness ) ,1-2 ( Color Temperature )
2	1-2 ( Brightness )	1-2 ( Brightness ) ,1-3 ( Color Temperature )
.....	.....	.....
16	1-16 ( Brightness )	1-16 ( Brightness ) ,2-1 ( Color Temperature )
17	2-1 ( Brightness )	2-1 ( Brightness ) ,2-2 ( Color Temperature )
.....	.....	.....
511	32-15 ( Brightness )	32-15 ( Brightness ) ,32-16 ( Color Temperature )
512	32-16 ( Brightness )	

## 9.Remote Control Mode(remote control for optional purchase)

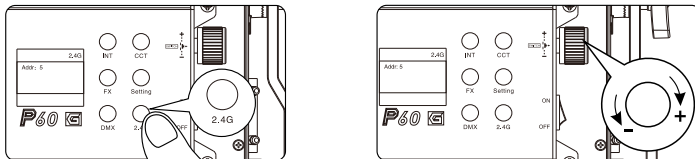

Press the 2.4G button to enter the remote control interface and rotate the selector knob to adjust the address. The remote control address adjustment range is 1-12, and the remote control address selection is synchronized with the light.

Noted: RMT-OFF means that the remote control function can not be used.

## 10.Setting Mode

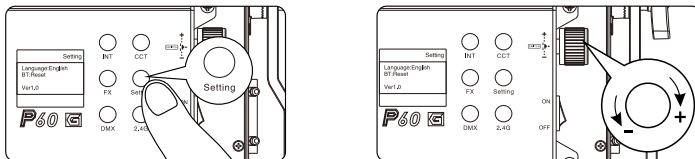

Press the setting button to enter the settings interface and short press the selector knob to switch between language and Bluetooth settings.

- Language switching: Rotate the selector knob to switch between Chinese and English options.
- Bluetooth settings: Before using the APP to control the lighting, rotate the selector knob to reset the Bluetooth of the lighting.

## 11.APP Control



Operation Instruction



Download in Apple Store

Users can search for "Light Reel" in the Apple store and Android market, or scan the QR code above to download APP to control the lighting.

## 12.Firmware Upgrade

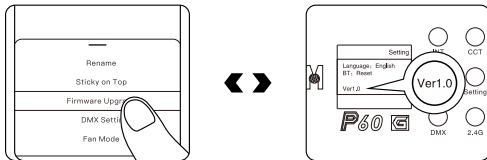

Users can upgrade their firmware through the Light Reel APP. After the upgrade is successful, they need to restart the lighting and enter the settings interface to view the current device version.

## 6.Product specifications

<b>Product model</b>	P60 [G]	P120 [G]
<b>Power</b>	60W	120W
<b>Beam angle</b>	120°	
<b>Color temperature</b>	2700K-6500K	
<b>CRI</b>	≥95	
<b>TLCI</b>	≥97	
<b>Rf</b>	Average 94	
<b>Rg</b>	Average 104	
<b>Working voltage</b>	AC power adapter:AC100V-240V , Light fixture:DC15V	
<b>Size</b>	360 x 413 x 79mm	600 x 413 x 79mm
<b>Weight</b>	4.2kg	5.8kg

### P60 [G] Illuminance data

Distance CCT	1m	2m	3m	4m	5m
<b>2700K</b>	1753 lux 163 fc	481 lux 45 fc	235 lux 22 fc	148 lux 14 fc	103 lux 10 fc
<b>3200K</b>	1904 lux 177 fc	517 lux 48 fc	259 lux 24 fc	162 lux 15 fc	112 lux 10 fc
<b>5600K</b>	2063 lux 192 fc	562 lux 52 fc	282 lux 26 fc	174 lux 16 fc	121 lux 11 fc
<b>6500K</b>	1970 lux 183 fc	543 lux 50 fc	271 lux 25 fc	170 lux 16 fc	118 lux 11 fc

## P120 [G] Illuminance data

Distance CCT	1m	2m	3m	4m	5m
<b>2700K</b>	3542 lux 329 fc	980 lux 91 fc	480 lux 44 fc	299 lux 27 fc	203 lux 18 fc
<b>3200K</b>	3650 lux 339 fc	1004 lux 93 fc	498 lux 46 fc	309 lux 28 fc	211 lux 19 fc
<b>5600K</b>	3890 lux 361 fc	1088 lux 101 fc	536 lux 50 fc	336 lux 31 fc	230 lux 21 fc
<b>6500K</b>	3704 lux 344 fc	1044 lux 97 fc	517 lux 48 fc	319 lux 30 fc	221 lux 21 fc

Product specifications are based on testing our laboratory samples. The product may vary slightly, however these variations will not affect normal use. The design and specifications are subject to change without notice.



---

☎ 0574-62763333/62636368    📠 0574-62636398    ✉ [ls@lishuai.com.cn](mailto:ls@lishuai.com.cn)

📍 No.55 East Zhenxing Road, Yuyao City Zhejiang Province, China