



TECHNICAL SPECIFICATIONS

Product Name :	Moisture-proof lamps
Model no:	XG-901/902/903/904
Power :	24W/20W/15W
Color :	White / Black
Input :	AC85-265V , 50 /60 HZ
Temperature range :	-20-50°C
Light source :	SMD2835
Lumen :	100 LM/W
Colour Temperture :	3000K - 6500K
Colour Rendering Index :	CRI>80
Beam angle :	120°
Power factor :	Pf>0.5 / Pf>0.9
Power efficiency :	92%
Housing material :	Plastic ABS
Cover material :	PS diffuser
Lighning protection :	1.5-4KV
Sealing material :	Gule
Protection class :	Ip65



XG-901

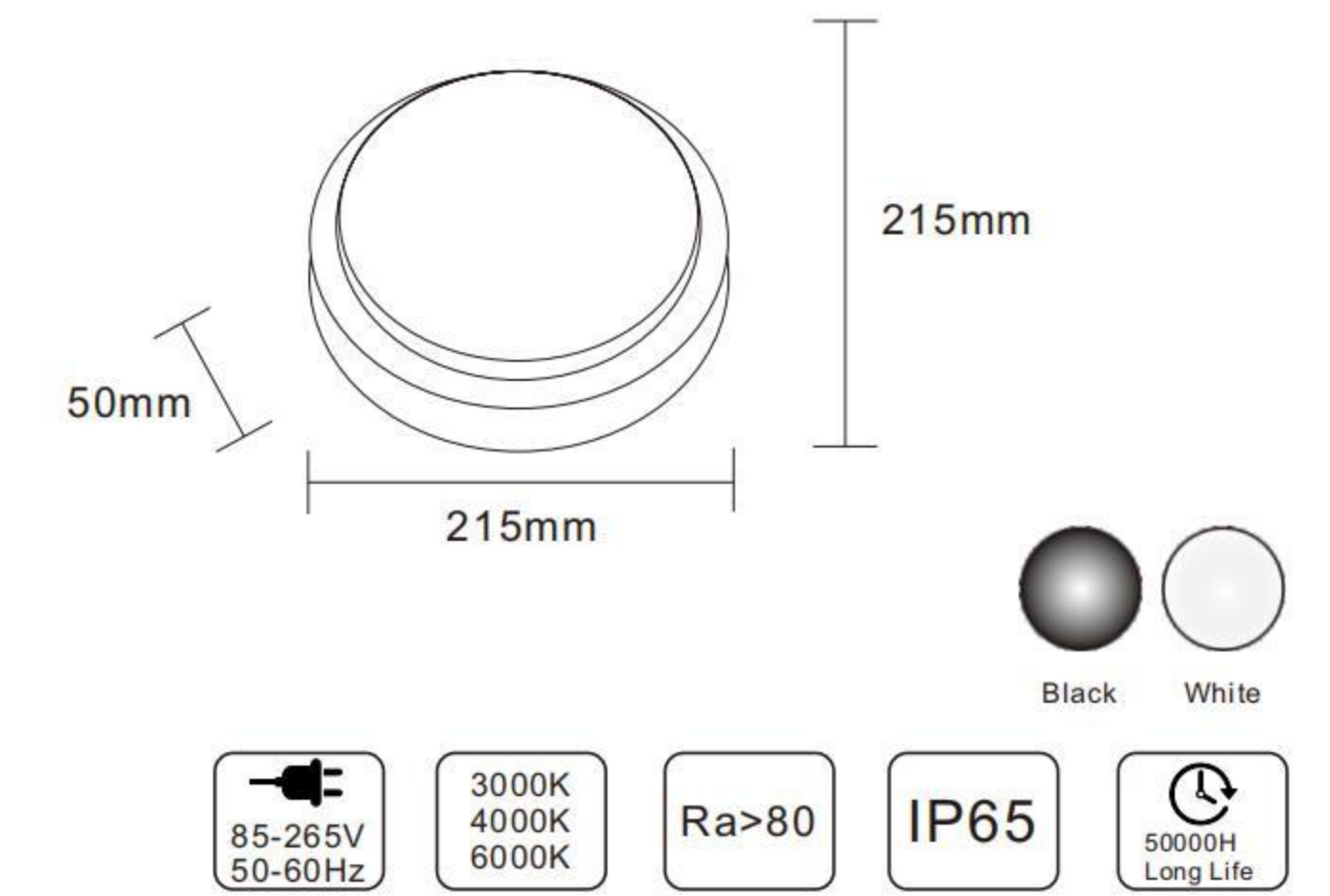

Item No	Power	Size	Input	Lumen	Material
XG-901	24W	Ø 215*H50mm	AC 85-265V 50-60Hz	100LM/W	ABS+PS
XG-902	15W	Ø 170*H50mm			

XG-903

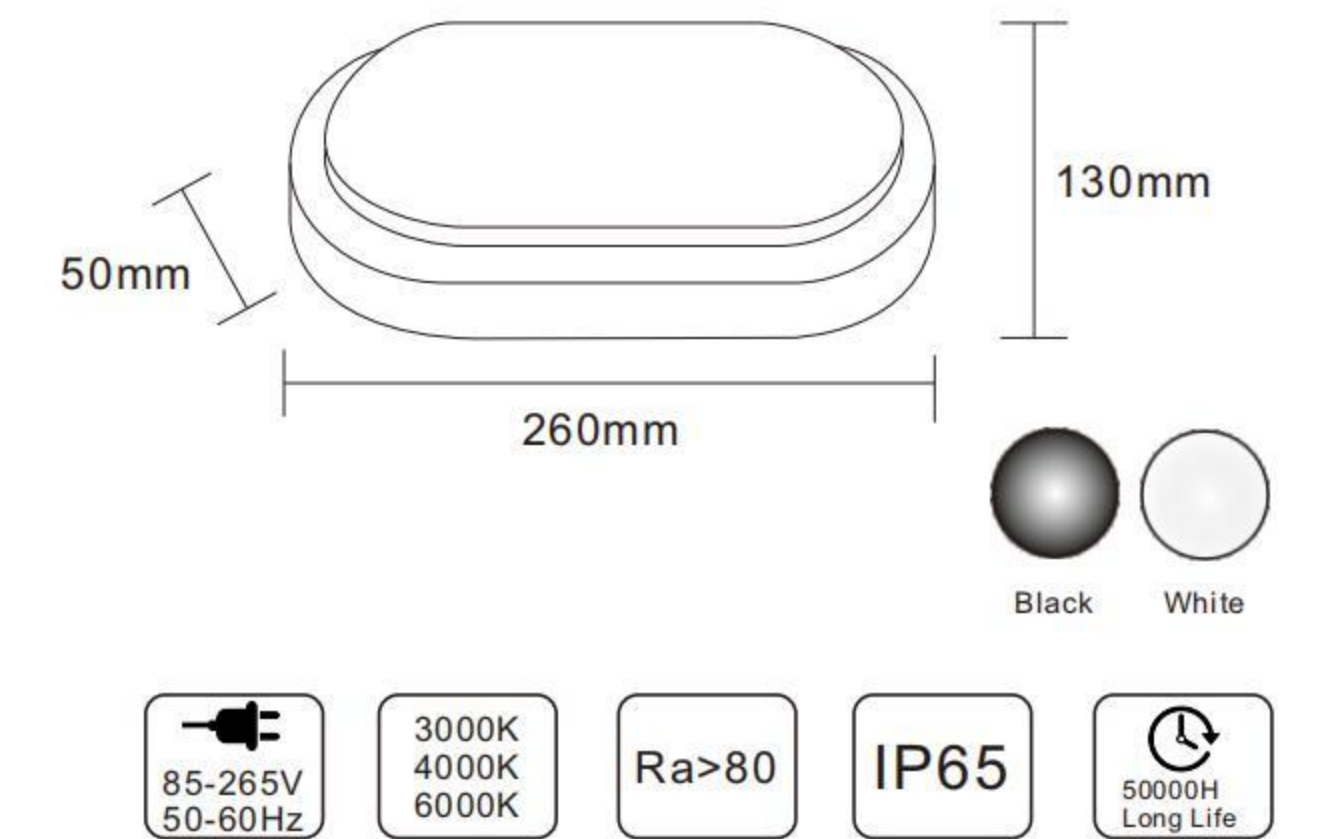

Item No	Power	Size	Input	Lumen	Material
XG-903	24W	L260*W130*H50mm	AC 85-265V 50-60Hz	100LM/W	ABS+PS
	20W				
XG-904	15W	L220*W110*H50mm			